



SERIES 927-072

ITS-Ex



IECEX/ATEX QUALIFIED HAZARDOUS ZONE CONNECTORS

IEC/EN 60079-0 • IEC/EN 60079-1 • IEC/EN 60079-31 • IEC/EN 60079-7 (PANEL MOUNT)

DECEMBER 2017



SERIES 927-072

ITS-Ex IECEx/ATEX Qualified Hazardous/Explosive Zone Connectors

Glenair is a qualified manufacturer of connectors for potential explosive zone use, built IAW IECEx/ATEX standards. The connectors may be used in application areas where flammable gases and vapors are present as a normal condition of operation (group IIC) and with temperature classes T6 and T5, zones 1 and 2; and for applications where potentially flammable dust is present as a normal condition of operation (group IIIC) and with temperature classes T80°C and T95°C in zone 21 and 22. The connector series design is optimized for fast and easy crimp-contact wire termination with ample wiring space in the cable housing and accessory hardware. Glenair Series ITS-Ex complies with the following standards:

- EN 60079-0 : 2012, "Explosive Atmospheres - Part 0: Equipment - General Requirements".
- EN 60079-1: 2014, "Explosive Atmospheres - Part 1: Equipment protection by flameproof enclosures 'd'".
- EN 60079-14: 2014, "Explosive Atmospheres - Part 14: Electrical Installations Design, Selection and Erection.
- EN 60079-31: 2014, "Explosive Atmospheres - Part 31: Equipment Dust Ignition Protection by Enclosure 't'".
- IEC 60079-0: 2011, "Explosive Atmospheres - Part 0: Equipment - General Requirements".
- IEC 60079-1: 2014, "Explosive Atmospheres - Part 1: Equipment Protection by Flameproof Enclosures 'd'".
- IEC 60079-14: 2013, "Explosive Atmospheres - Part 14: Electrical Installations Design, Selection and Erection.
- IEC 60079-31: 2013, "Explosive Atmospheres - Part 31: Equipment Dust Ignition Protection by Enclosure 't'".
- For panel mount complies also with: EN/IEC 60079-7: 2015, "Explosive Atmospheres - Part 7: Equipment protection by increased safety 'e'".

- Over 40 power and signal contact arrangements
- Full support for common armored and unarmored cable types
- MIL-DTL-5015 crimp-contact derivative solution
- Locking set screw-equipped coupling nut and protective safety covers
- Extended shell labyrinth cooling zone and potting chamber features
- Mechanical cable clamp, basket weave, and Ex d cable gland accessories
- IP68 water, vapor, moisture and dust protection in mated condition

SERIES 927-072 ITS-Ex Hazardous Zone Connectors



Table of Contents



General Information and Series Specifications

Page 4



ITS-Ex Plugs

Page 36



ITS-Ex Fixed In-Line Receptacles

Page 44



ITS-Ex In-Line Receptacles

Page 52



ITS-Ex Panel Mount Fixed Receptacles

Page 60



Contacts, Tools and Accessories

Page 62

Zone and category designations

ATEX EXPLOSIVE ZONES AND CATEGORIES

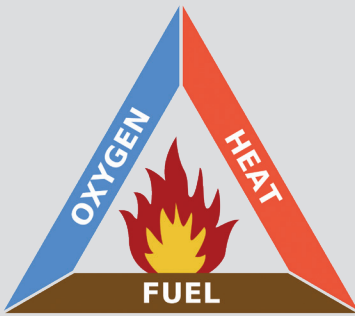

Explosion Triangle

Purpose of explosion zone connectors and glands

Glenair Series 927-072 ITS-Ex Hazardous Zone Connectors prevent explosions by eliminating the heat component in the explosion triangle. This is accomplished by preventing an ignition source, such as a flame or spark, from migrating through the cable or connector into a defined hazardous zone such as might be found in a petrochemical refinery or land/offshore drilling system. Hazardous zones are defined by frequency of presence of explosive gas or dust.

Hazardous Zone Fuel Types

- Gas, vapor and mists : methane, butane, ethylene, hydrogen, acetylene
- Dust : aluminum, sulfur, zinc, grain, coal, sugar, epoxy resin

In the ATEX 1999/92/EC directive, hazardous areas are divided into three defined zones: 0, 1, and 2. These zones are designations used to describe the likelihood that explosive mixtures of fuel and oxygen exist during normal conditions of facility operation.

Zone 0 (20)	Zone 1 (21)	Zone 2 (22)
Area in which an explosive gas (dust) atmosphere is present continuously or for long periods or frequently.	Area in which an explosive gas (dust) atmosphere is likely to occur in normal operation occasionally.	Area in which an explosive gas (dust) atmosphere is likely to occur in normal operation but, if it does occur, will persist for a short period only.

Explosive area zone classifications are used by the operator to distinguish between explosive areas and their relative levels of risk. Operators use the triangular EX mark to indicate compliance with IECEx/ATEX requirements. Manufacturers however use different classifications to describe where their products may be used. The two systems generally conform in meaning but the words and symbols change.

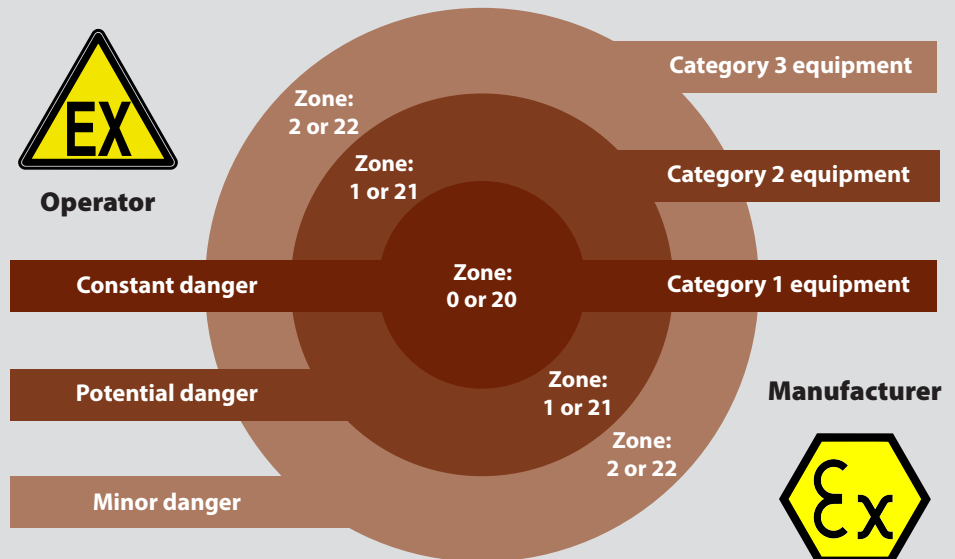

Zone and category designations

Glenair Connectors 927-072 are qualified for Group IIA, IIB, IIC and for Group IIIA, IIIB, IIIC, Category 2 and Category 3.

A connector qualified for Group IIC cover from IIC to IIA.

A connector qualified for Group IIIC cover from IIIC to IIIA.

Category 2	Category 3
Place where explosive atmosphere is likely to occur. Provides the protection level in case of failure of the connector/equipment.	Place where explosive atmosphere are unlikely to occur, or if they do occur not frequently and only for a short period of time. Provides the requisite level of protection during normal operation.

GROUP II is for explosive GASES for surfaces industries

Group II	Gases
IIA	Acetone, ethyl alcohol, ammonia, gasoline, butane, hexane, ethanol, natural gas, methanol, propane
IIB	Acetaldehyde, propane, ethylene
IIC	Hydrogen, gas mixture containing more than 25% hydrogen, acetylene, carbon disulphide

GROUP III is for explosive DUST for surfaces industries

Group III	Dust
IIIA	Fibers
IIIB	Non-conductive dust
IIIC	Conductive dust

TEMPERATURE CLASSES

Glenair Series 927-072 ITS-Ex Hazardous Zone Connectors are IAW qualified for class T6 or class T5.

The equipment is certified only for use in temperature class T6 with ambient temperature between -40°C to +40°C max or the equipment is certified only for use in temperature class T5 with ambient temperature between -40°C to +55°C max.

The equipment should not be used in an explosive environment outside of this range.

A connector with a temperature class of T6 covers from T6 to T1 (but the ambient temperature must be from -40°C to +40°C max).

A connector with a temperature class of T5 covers from T5 to T1 (but the ambient temperature must be from -40°C to +55°C max).

Temperature Class	Permissible surface temperatures of the electrical equipment	Ignition temperature of the combustible gases
T1	450 °C	> 450 °C
T2	300 °C	300 - 450 °C
T3	200 °C	200 - 300 °C
T4	135 °C	135 - 200 °C
T5	100 °C	100 - 135 °C
T6	85 °C	85 - 100 °C

Zone and category designations

IEC AND ATEX

ATEX 2014/34/EU directive classifies the equipment into categories 1,2,3 (Group II), based on protection level. Standard EN/IEC 60079-0 introduces EPL (Equipment Protection Level).

ATEX Group II	EPL according to IEC/EN 60079-0	
	Gas	Dust
Category 1	Ga	Da
Category 2	Gb	Db
Category 3	Gc	Dc

The relation between the ATEX 1999/92/EC and the IEC is indicated below : in the Zone 0 you could mount an equipment Ga or 1G (according to 94/9/EC ATEX).

Atmosphere	Zone	EPL	ATEX Category
Gas	0	Ga	1G
	1	Gb or Ga	2G or 1G
	2	Gc or Gb or Ga	3G or 2G or 1G
Dust	20	Da	1D
	21	Db or Da	2D or 1D
	22	Dc or Db or Da	3D or 2D or 1D

RANGE OF APPLICATIONS

- Automotive refuelling or petrol stations
- Oil & gas extraction
- Oil refineries
- Gas pipelines and distribution
- Chemical processing plants
- Aircraft refuelling and hangars
- Transportation
- Pharmaceuticals
- Food processing
- Metal surface grinding
- Sugar refineries
- Grain handling and storage
- Coal mining



ITS-Ex Series labeling and materials

TECHNICAL OVERVIEW

Certified Uses:

- **With flammable gases and vapors with apparatus group IIC and with temperature classes T6 and T5 in zones 1 and 2**
- **With flammable dusts with apparatus group IIIC and with temperature classes T80°C and T95°C in zone 21 and 22**
- **The connectors are certified IP68 (tested at a depth of 10 meters for 30 minutes)**
- **Mechanical Durability at Ambient Temperature. No deterioration which will adversely affect the connector after 500 cycles of mating and unmating**

The Glenair ITS-Ex Hazardous Zone series of connectors is comprised of metallic bodies and shells (aluminium alloy standard, for optional materials ask to the factory) with resilient silicone rubber inserts IAW MIL-DTL-5015. Pin or socket crimp contacts are available, and male and female inserts are reversible. Cable plugs and receptacles are available to form in-line cable connections. A fixed flange mount receptacle is available for Ex d boxes and Ex e bulkhead use. Connectors are coupled with a trapezoidal double-start threaded nut retained by grub (set) screws, and form a cylindrical flamepath when mated. When disconnected, plugs and receptacles are mated to an attached, by stainless steel wire rope, protective safety cap (or blanking cap). Absence of cap voids the Ex certification. Mate plug and receptacle caps together when not in use to prevent thread damage. Both plug and receptacle cable configurations are equipped with back-end accessory threads for the attachment of mechanical cable clamps and wire mesh Kellems grip-style attachments (potting required). A third style of rear-end accessory, an industry-standard Ex-certified explosion-proof cable gland, is also available and supplied by Glenair. The Ex certified cable gland does not require potting by the customer to achieve Ex d certified performance.

ATEX / IECEx LABELS

All Glenair ITS-Ex connectors are supplied with a non-removable label contains the following information per ATEX and IECEx directives:

FOR IN-LINE CONNECTOR AND PANEL MOUNT EQUIPMENT:

ATEX Marking

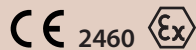

II 2 G Ex db IIC T6, T5 Gb
 II 2 D Ex tb IIIC T80°C, T95°C Db IP68
 -40°C ≤ Tamb ≤ +40°C (T6, T80°C) or +55°C (T5, T95°C)

IECEx Marking

Ex db IIC T6, T5 Gb
 Ex tb IIIC T80°C, T95°C Db IP68
 -40°C ≤ Tamb ≤ +40°C (T6, T80°C) or +55°C (T5, T95°C)

FOR PANEL MOUNT COMPONENT FIXED RECEPTACLES ONLY:

ATEX Marking



II 2 G Ex db eb IIC Gb
 II 2 D Ex tb IIIC Db IP68
 -40°C ≤ Tservice ≤ +100°C

IECEx Marking

Ex db eb IIC Gb
 Ex tb IIIC Db IP68
 -40°C ≤ Tservice ≤ +100°C

Equipment label is laser printed white on black background.

Equipment label is laser printed black on silver background.

Materials	
Item	Material
Hardware Body	Standard Base Material: aluminium alloy EN AW 6082-T6 UNI EN 573-3 (0.7÷1.3% Si, 0.6÷1.2% Mg, <0.2% Ti). All aluminium parts finished with a hard, scratch-resistant coating per MIL-A-8625, type III, class 2.
Insert	Silicone rubber
Cable Seal Glands	Silicone rubber
Grommet and Gasket	Silicone fire resistant rubber
O-Ring	Silicone MVQ / VMQ
Grub Screws (Set Screws)	UNI EN 10088-3, Alloy 316, stainless steel, passivated
Crimp Socket and Pin Contacts	Copper alloy ISO CuZn37Pb2/CuZn35Pb2 (OT61B/OT62A) for size AWG 16, 12 and 8 and copper alloy ISO CuTe for size 4,0. Both of them are silver plated as standard and gold plated as option.
Cement for potting	Bi-component epoxy resin (applied by the customer), flame retardant and thermally conductive, cure at room temperature for 24 hours.

Connector configurations

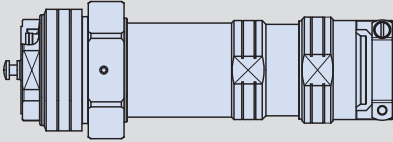
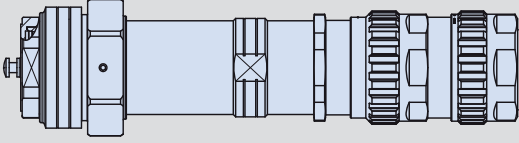
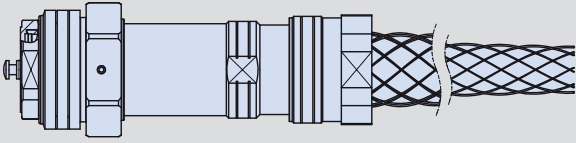
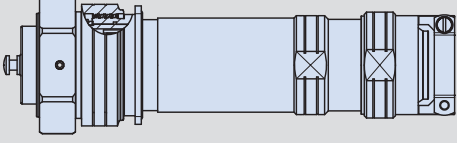
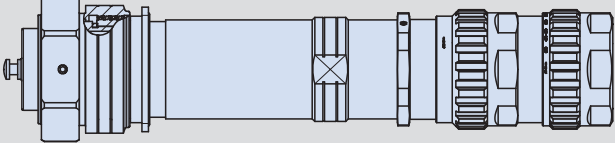
Connectors Configurations	Base Part Number and Description
<p data-bbox="134 457 643 485">Plug with Mechanical Clamp and Potting Well</p> 	<p data-bbox="805 457 959 485">927-072-016-</p> <p data-bbox="805 506 1463 705">Plug with mechanical cable clamp and potting well: 927-072-016 incorporates a potting well /cable adapter which must be filled with supplied 2-part epoxy for certified Ex d performance. Various cable entry sizes for popular armored and unarmored cables are supported. Protective safety cover included.</p>
<p data-bbox="134 730 448 758">Plug with Ex d Cable Gland*</p>  <p data-bbox="115 961 751 1041">(*)This product may also be acquired without a cable gland, in this case the user is responsible for the choice of an appropriate cable gland. For further information please contact the factory.</p>	<p data-bbox="805 730 959 758">927-072-026-</p> <p data-bbox="805 779 1463 978">Plug with “Ex d” certified cable gland (potting is not required): 927-072-026 is supplied with an industry-standard Ex d certified cable gland, ready for immediate use. Various cable entry sizes for popular armored and unarmored cables are supported. Protective safety cover included.</p>
<p data-bbox="134 1077 524 1104">Plug with Basket Weave Cable Grip</p> 	<p data-bbox="805 1077 959 1104">927-072-036-</p> <p data-bbox="805 1125 1463 1325">Plug with basket-weave cable grip and potting well: 927-072-036 incorporates a potting well /cable adapter which must be filled with supplied 2-part epoxy for certified Ex d performance. Various cable entry sizes for popular armored and unarmored cables are supported. Protective safety cover included.</p>
<p data-bbox="134 1350 675 1377">Fixed In-Line Receptacle with Mechanical Clamp</p> 	<p data-bbox="805 1350 959 1377">927-072-012-</p> <p data-bbox="805 1398 1463 1598">Fixed in-line receptacle with mechanical cable clamp and potting well: 927-072-012 incorporates a potting well /cable adapter which must be filled with supplied 2-part epoxy for certified Ex d performance. Various cable entry sizes for popular armored and unarmored cables are supported. Protective safety cover included.</p>
<p data-bbox="134 1623 670 1650">Fixed In-Line Receptacle with Ex d Cable Gland*</p>  <p data-bbox="115 1881 751 1961">(*)This product may also be acquired without a cable gland, in this case the user is responsible for the choice of an appropriate cable gland. For further information please contact the factory.</p>	<p data-bbox="805 1623 959 1650">927-072-022-</p> <p data-bbox="805 1671 1463 1871">Fixed in-line receptacle with “Ex d” certified cable gland (potting is not required): 927-072-022 is supplied with an industry-standard Ex d certified cable gland, ready for immediate use. Various cable entry sizes for popular armored and unarmored cables are supported. Protective safety cover included.</p>

Connector configurations

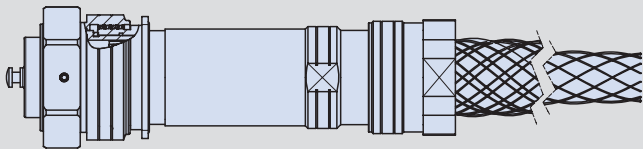
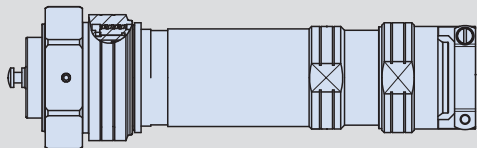
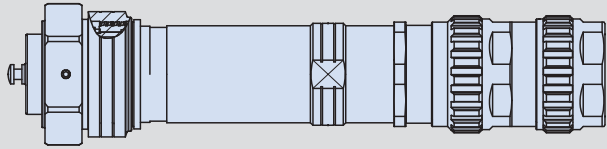
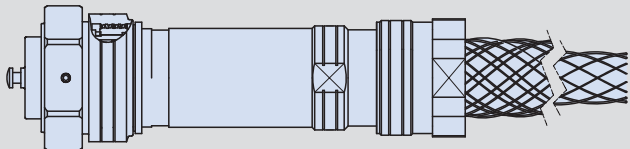
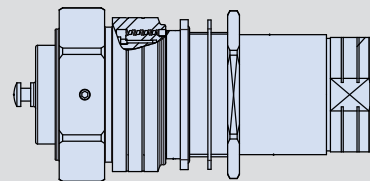
Connectors Configurations	Base Part Number and Description
<p data-bbox="170 453 623 483">Fixed In-Line Receptacle with Cable Grip</p> 	<p data-bbox="839 453 993 480">927-072-032-</p> <p data-bbox="839 499 1498 699">Fixed in-line receptacle with basket-weave cable grip and potting well: 927-072-032 incorporates a potting well/cable adapter which must be filled with supplied 2-part epoxy for certified Ex d performance. Various cable entry sizes for popular armored and unarmored cables are supported. Protective safety cover included.</p>
<p data-bbox="170 720 712 749">In-Line Receptacle with Mechanical Cable Clamp</p> 	<p data-bbox="839 720 993 747">927-072-011-</p> <p data-bbox="839 766 1498 966">In-Line receptacle with mechanical cable clamp and potting well: 927-072-011 incorporates a potting well/cable adapter which must be filled with supplied 2-part epoxy for certified Ex d performance. Various cable entry sizes for popular armored and unarmored cables are supported. Protective safety cover included.</p>
<p data-bbox="170 987 639 1016">In-Line Receptacle with Ex d Cable Gland*</p>  <p data-bbox="147 1213 789 1291">(*)This product may also be acquired without a cable gland, in this case the user is responsible for the choice of an appropriate cable gland. For further information please contact the factory.</p>	<p data-bbox="839 987 993 1014">927-072-021-</p> <p data-bbox="839 1033 1498 1232">In-Line receptacle with “Ex d” certified cable gland (potting is not required): 927-072-021 is supplied with an industry-standard Ex d certified cable gland, ready for immediate use. Various cable entry sizes for popular armored and unarmored cables are supported. Protective safety cover included.</p>
<p data-bbox="170 1329 716 1358">In-Line Receptacle with Basket Weave Cable Grip</p> 	<p data-bbox="839 1329 993 1356">927-072-031-</p> <p data-bbox="839 1375 1498 1612">Flange-mount receptacle with basket-weave cable grip and potting well: 927-072-031 incorporates a potting well/cable adapter which must be filled with supplied 2-part epoxy for certified Ex d performance. Various cable entry sizes for popular armored and unarmored cables are supported. Protective safety cover included.</p>
<p data-bbox="170 1638 672 1667">Panel-Mount Fixed Receptacle Component**</p> 	<p data-bbox="839 1638 993 1665">927-072-003-</p> <p data-bbox="839 1684 1498 1921">Panel mount fixed receptacle with potting well: 927-072-003 is designed for use in certified Ex d flame-proof enclosures. An auxiliary lock nut is supplied for blowout protection in Ex e increased safety enclosures. The receptacle incorporates a potting well which must be filled with supplied 2-part epoxy for certified Ex d performance. Protective safety cover included.</p>

(**) The device can be used also as equipment with part number 927-072-004

Mating-End Cross-sectional and exploded views

MATING-END CROSS-SECTIONAL VIEWS

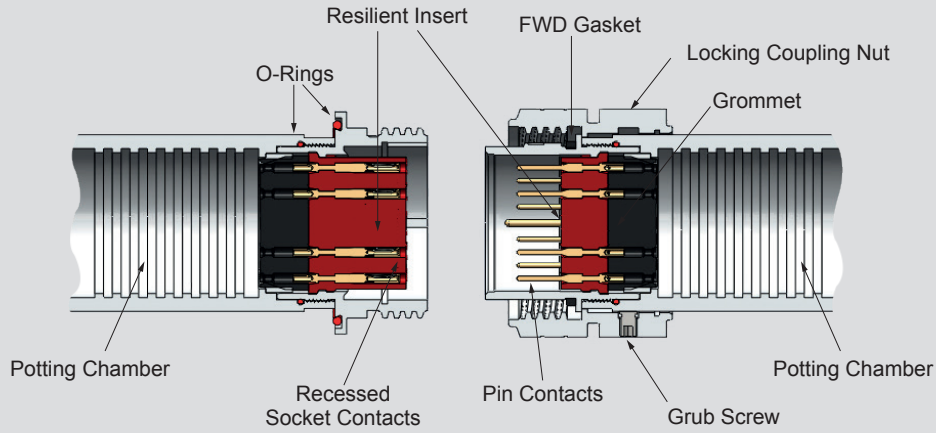

Receptacle (left) and Plug (right) connector pair

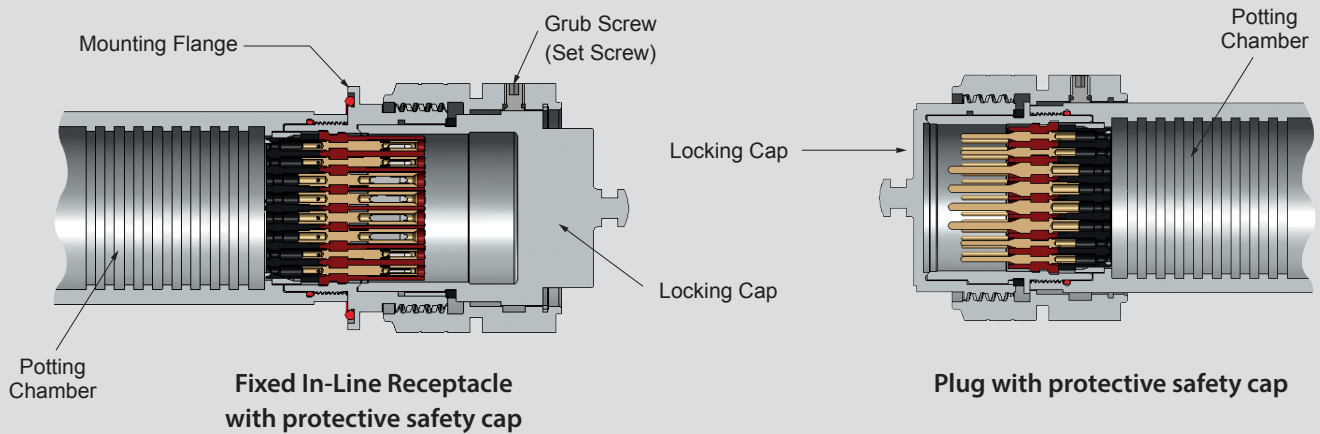

Fixed In-Line Receptacle with protective safety cap

Plug with protective safety cap

EXPLODED VIEWS

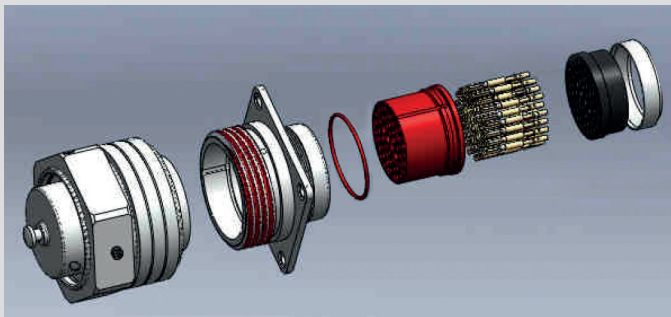

Receptacle

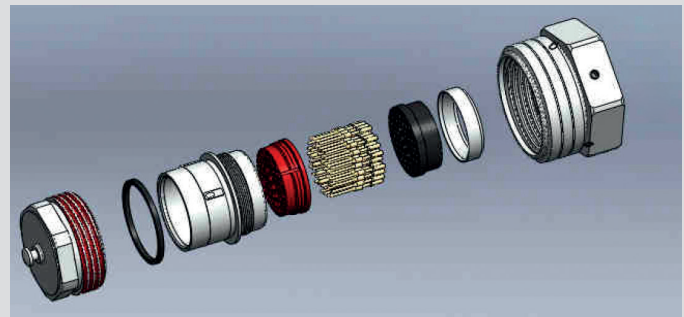

Plug

Receptacle Panel Mount Connector Assembly

CONFIGURATIONS

The Receptacle panel mount connector is a bulkhead mounted version (panel mount configuration) that contains an externally threaded flamepath for mounting to certified explosion proof enclosures devices (“Ex d”) with suitable internal mating thread and have externally gaskets to certified explosion proof increased safety enclosure (“Ex e”). It is also suitable for no Ex threaded and unthreaded panel interface with a specific certification.

The Glenair Panel Mount explosion proof series of connectors is comprised of metallic (aluminium alloy as standard) receptacle shells, to form connections with only Glenair in-line explosion proof connector plug shell.

The panel mount receptacle and a plug shells when mated form an in-line connection.

Externally the main bodies aren’t fitted with cable glands. The body of this version must be internally potted with bi-component epoxy resin.

This product has two types of certifications the first one as Component and the second one as Equipment.

Series 927-072-003 can be used such as additional component for customer device which have to test overall. A product certified and marked such as Component must be used or installed on a box with Ex d or Ex e certification.

Series 927-072-004 can be used such as stand-alone equipment for customer panel interface (NO “EX” PANEL) which have not to test. A product certified and marked as Equipment must be used or installed on a panel. The device had already a certification with its assigned temperature class.

Internally the main bodies each contain an insulator insert fitted with crimp type contacts of either a pin or socket variety (female and male inserts are reversible).

When connected together they form a cylindrical flamepath and are mechanically interlocked by means of a threaded nut (trapezoidal double start thread) retained by a grub screws. When not connected, each connector is mated to a safety environmental cap and the corresponding joint is a cylindrical flamepath, mechanically interlocked by trapezoidal double start thread and grub screws.

The range is comprised of six body sizes (10SL, 14S, 16, 18, 28, 36), each with a number of pin/socket size combinations between 1 and 56 contacts.

The connector shell size, contacts configuration and rating are reflected in the individual type designations.

Some design options could be alternative keying options, and pin or sleeve contacts in receptacle bodies.

The connectors are certified IP68 (tested at a depth of 10 meters for 30 minutes).



PANEL MOUNT			
SERIES 927-072-003- COMPONENT No Temperature Class		SERIES 929-072-004- EQUIPMENT Temperature Class	
On Panel with “Ex” Interface		On Panel no “Ex” Interface	
Ex “d” Interface	Ex “e” Interface	Jam Nut Type	Screw Type

Receptacle Panel Mount Connector Assembly

FOR Ex "e" PANEL APPLICATIONS (JAM NUT TYPE)

Use the flat panel gasket, and jam nut both supplied by Glenair.

1. As is typical in all gasketing applications, clean all mating surfaces: back of flange, front and back mating surfaces of panel, faces of gasket and mating face of jam nut.
2. Mount gasket to back of connector flange.
3. Install the connector through panel, positioning as required.
4. Install and run jam nut to panel.
5. Tighten jam nut fully, by hand, so the connector is solidly pressed against the panel and the gasket is captured.
6. To complete tightening, turn the jam nut an additional 1/4 turn using an appropriate tool.
7. In applications where vibration is anticipated, a second jam nut could be used to lock the primary jam nut in place.
8. Thread locking compound (Loctite 242, blue, or equal), per the compound suppliers recommendations, can be used on any of the threads without impacting flamepath function.

For all increased safety panel mount receptacles: in accordance with IEC/EN 60079-7:2015, Clause 7.1, the increased safety enclosure certificate must include the use of the device as well as an electric strength test on the finished assembly.

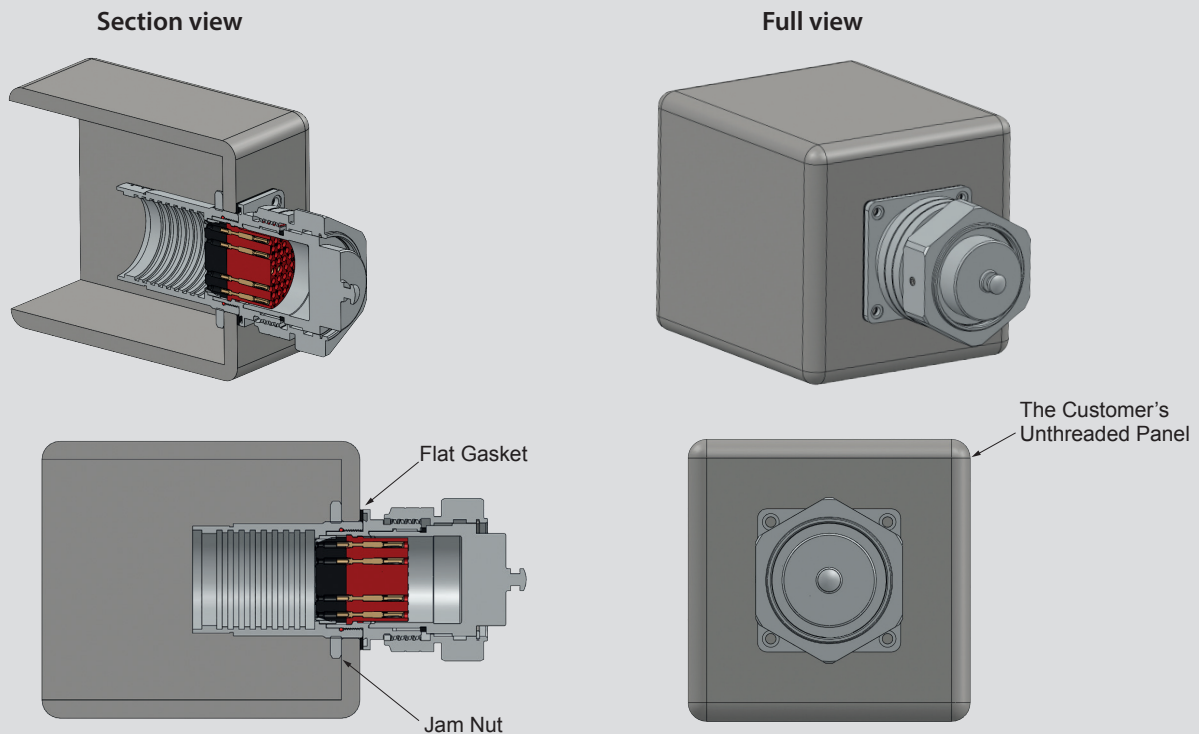

Receptacle Panel Mount Connector Assembly

FOR Ex "d" BULKHEAD APPLICATIONS (SCREW TYPE)

The panel adapter / potting chamber has external threads that are flamepath. For the minimum thickness of the customer panel [mm] see table 13 of the Glenair instruction manual D500500002.

Ex "d" applications require an enclosure that is Ex "d" rated. For this case, the included o-ring is used, and the flat gasket is omitted.

1. With the o-ring installed onto the back of the receptacle flange, thread the receptacle assembly into the mating flameproof thread on EX "d" approved enclosure. The thread on the enclosure shall be identified as a threaded flamepath, and suitable to accept either EX certified cable glands or Ex proof connectors.
2. It is best to fit the connector to the bulkhead at a time when the free end of the cable is not terminated to the electrical system. If this is not possible, then it is necessary to rotate the connector assembly counter-clockwise to wind the cable / conductors so that when the assembly is threaded into a bulkhead in the subsequent instruction, the cable/conductors regain their most natural lay, once the connector is mounted to the bulkhead. (Rotations required to be determined by end-user).
3. Thread the connector into the bulkhead by hand, stopping at the point where the o-ring just touches down onto the bulkhead surface.
4. Turn the connector an addition amount so that the mounting holes in the flange, line up with the blind threaded holes in the enclosure. If after touching down the o-ring, the holes happen to line up with less than a 1/4 turn, advance the receptacle until the next holes line up.
5. Secure the connector to the enclosure using M5 fasteners.
6. Thread locking compound (Loctite 242, blue, or equal), per the compound suppliers recommendations, can be used on any of the threads without impacting flamepath function.

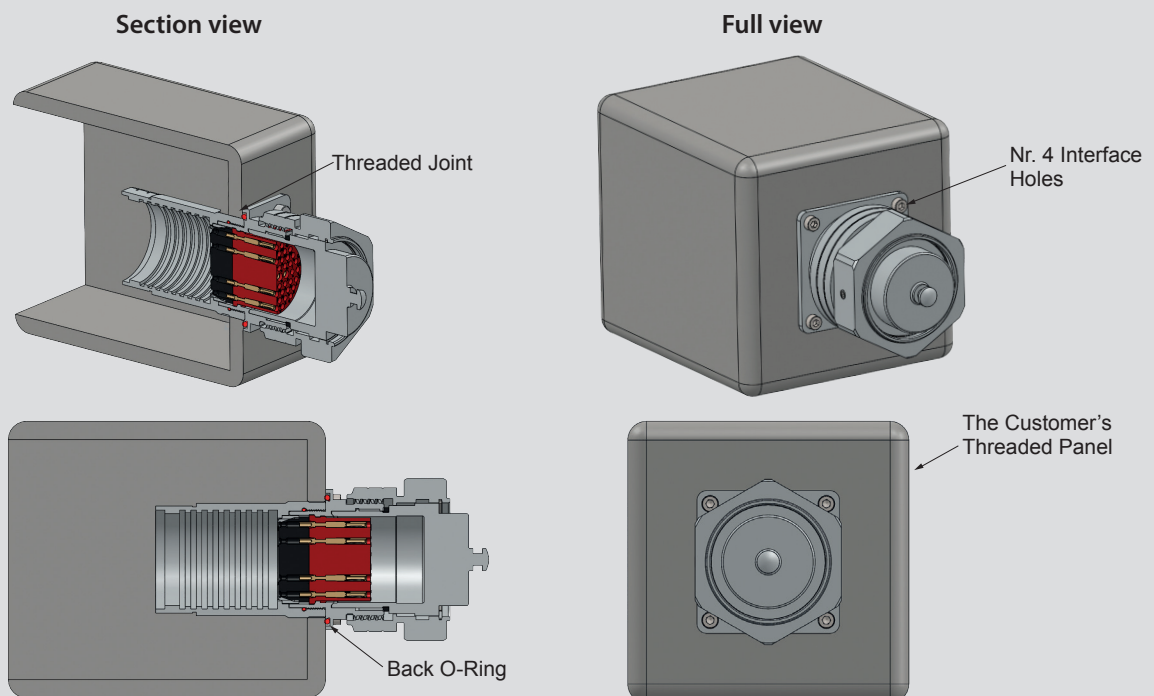

ITS-Ex operation best practices

SPECIAL CONDITIONS OF SAFE USE

The following conditions shall be met for safe use of Series ITS-Ex connectors.

1. Male and female connectors are considered completely mated when the plug coupling nut is fully advanced on the receptacle, and all grub screws are secured.
2. Use Loctite 242 or equivalent (medium strength threadlocker) at threaded joints between the following: plug shell and cable adapter (backshell); receptacle shell and cable adapter (backshell); cable adapter (backshell) and certified cable gland.
3. Never demate connector halves when energized or remove protective safety covers when an explosive gas or dust atmosphere is present.
4. When a connector half fitted with contact pins is not connected to an associated plug or receptacle, it shall not be energized, per IEC 60079-0, clause 20.2.
5. Use protective safety covers whenever connector halves are not mated, being careful to always advance and secure the grub screws. Flame-proof safety caps are a part of the certification, and their use is required to maintain independent flameproof worthiness of the connector halves.
6. When a connector half fitted with socket contacts is not mated to an associated plug or receptacle, it shall not be re-energized unless it is fitted with an flameproof protective safety cover.
7. Perform connector backpotting step according to Glenair instruction manual D500500000 for In-Line and D500500002 for Panel Mount version. Backpotting, or use of an Ex d certified cable gland is required for all Hazardous Zone rated equipment and shall be performed carefully and properly, using the 2-part epoxy compound supplied with each connector.
8. Always use suitable cable with a minimum rated operating temperature of 90°C when using rated current according to N.E.C. It is the responsibility of the operator to ensure selected cable is suitable for use in each specific application, including resistance to aggressive substances and caustic chemicals.
9. Always use suitable cable with a minimum rated operating temperature of 100°C when using rated current extrapolated from VG95234. It is the responsibility of the operator to ensure selected cable is suitable for use in each specific application, including resistance to aggressive substances and caustic chemicals.
10. It is not possible to connect to a battery without using a circuit breaker.
11. Series ITS-Ex connectors do not incorporate an external earth/ground. It is the responsibility of the user or installer to ensure adequate earth/ground continuity IAW Glenair instruction manual D500500000 for In-Line and D500500002 for Panel Mount version.
12. Do not remove Ex marking label and its lanyard from connector body or protective safety cover. For flange-mount receptacles mounted to a panel, attach label lanyard directly to a flange mounting hole. Label is required for identification of connector in a certified Ex d application.
13. For multi-pin connectors, calculate current load and temperature rise based on ambient temperature plus the aggregate total of the individual contacts in the insert. MIL-W-5088 specifications shall be used as reference on the subject in as much as pertinent cable de-rating data is included.

SERIES 927-072 ITS-Ex Hazardous Zone Connectors



Cable application notes

CABLE CROSS-SECTION AND INTERNAL CONSTRUCTION

There are no IEC construction standards for the cables intended for use in flammable atmospheres, but minimum cable operating temperature shall be 90°C IAW NEC / 100°C VVG95234. Gas-tight sealing of cabling for use in Ex d equipment enclosures depends heavily on cable shape and construction. Please see Glenair Instruction Manual D500500000 for In-Line and D500500002 for Panel Mount version, for complete information on cable selection, noting that any selected cable should:

1. Be substantially compact and circular (especially the part of the cable entering the enclosure),
2. Have an extruded bedding (without any gaps),
3. Only utilize fillers which are Non-Hygroscopic.

In this illustration, **Cable A** is not suitable due to its irregular shape (impossible for cylindrical sealing gasket to seal).

Cables B, D and E are not suitable due to the presence of internal voids in the cable construction (potential flame migration path between conductors).

Cable C is the only one of the five sample cables illustrated which could be selected (uniformly round with no internal voids or gaps in cable lay or construction).

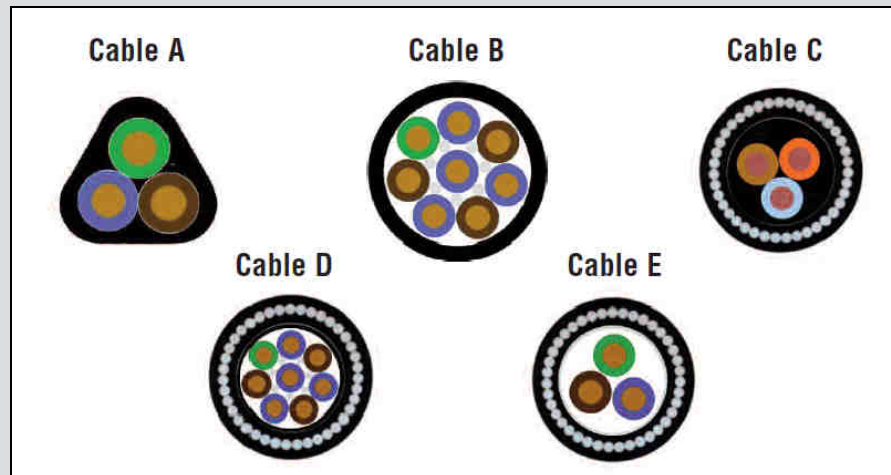

GROUNDING

Glenair ITS-Ex connectors do not incorporate external grounding/earthing. It is the responsibility of the operator to effect earth continuity during the assembly process. Various methodologies, such as terminating a ground wire to a spare connector contact may be used for signal grounding and continuity. Electrical grounding of the cable armour system may be accomplished with the use of soldering, heat shrink, adhesive electrical tapes, or other methodologies to bond cable armoring to ground.

Glenair recommends that a small strip of outer jacket be cut away a reasonable distance from the entrance to the cable gland servicing the connector. A durable insulated conductor with a cross section not smaller than #14 AWG/4mm should then be bonded to the exposed armour. Protective tape, heat or cold shrink should be applied to protect and seal the bond point. The grounding conductor should be terminated at a fixed-panel receptacle. Periodic inspection of the ground attachment is recommended.

Cable application notes

ARMORED AND UNARMORED CABLE SELECTION AND USE

It is the responsibility of the operator to select appropriate cables for use in hazardous Ex zones. Glenair recommends cables optimized for flexibility (IEC class 5 or higher / ICEA type H or higher) that incorporate flexible basket weave braided shielding when armoring is required (IEC 92-3 or IEEE455 or UL1309). Cables incorporating environmental jacketing, such as those in the following list should always be specified.

1. Halogen free ethylene-propylene elastomer or similar.
2. Halogen free cross-linked polyethylene or similar.
3. Halogen free thermoplastic polyolefin or similar.
4. Halogen free cross-linked polyolefin copolymer or similar.
5. Thermosetting neoprene or similar.

Glenair ITS-Ex cable glands, mechanical grips, and basket weave assemblies support cable diameter ranges from 52mm to 3mm, depending upon shell size. Some example of types of cable jacket and insulation cores materials are as follows (typical for marine, railway, onshore and offshore applications):

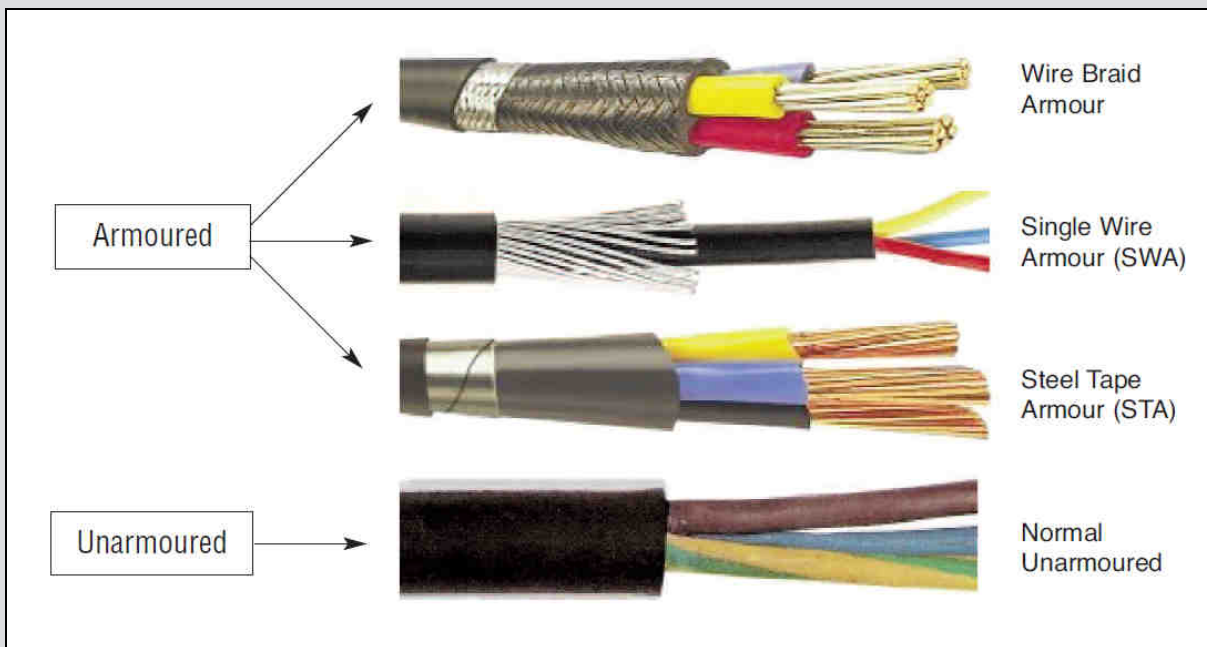

In this illustration, among the three armored types shown, Glenair recommends flexible Wire Braid Armor type cables. Single Wire Armor (SWA) and Steel Tape Armor (STA) cable types are not recommended. Standard unarmoured cable is suitable for use in non-EMI/RFI applications and/or applications where risks of mechanical damage to cable conductors are minimal.

Potting materials and instructions for In-Line and Plug configuration

EPOXY RESIN POTTING MATERIAL

Glenair ITS-Ex series connectors equipped with an Ex barrier gland do not require potting. All other configurations, including mechanical cable clamp, basket weave backshell, and fixed flange receptacles must be potted for Ex certification. Connectors are supplied with a 2-part epoxy resin material for this purpose. This cement is both flame retardant and thermally conductive, fully cures at room temperature in 24 hours, and hardens after 4 hours. The material has a mix ratio by weight equal to 100 parts of resin to five parts of activation catalyst. The material is supplied in pre-measured flexible packs. It is the operator's responsibility to evaluate whether any caustic chemicals or other aggressive substances present in the facility might damage the performance of the potting material.

MIXING INSTRUCTIONS

1. Check expiration date of potting material before proceeding
2. Wear appropriate eye protection
3. Connector and cable should be fully terminated and prepped for potting prior to material mixing
4. Follow all flexible pack mixing instructions, note mixing time is approximately 5 minutes

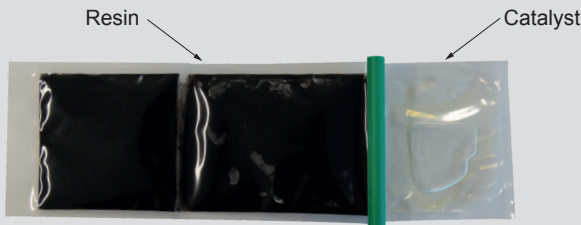

Fill Depth Illustration and Table

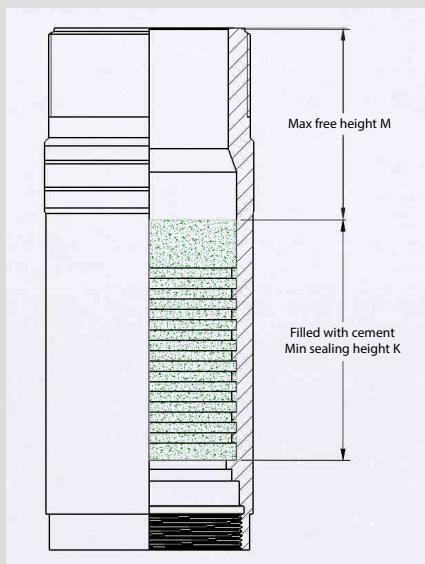

1.

Remove the clip from plastic pouch.

2.

Apply pressure to mix resin and catalyst.

3.

Mix thoroughly on table edge or any 90 degree surface until well mixed.

4.

Cut corner and dispense.

Illustration of Fill Depth in relation to Jacketed and Stripped Cable zones

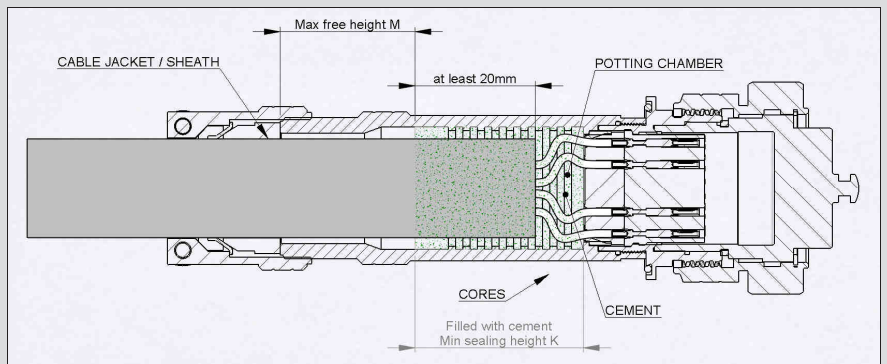

Shell Size	36	28	18	16	10SL
Min sealing height K [mm]	61	60	57	60	32
Max free height M [mm]	65	48	23	18	23

Potting materials and instructions for Panel Mount configuration

POTTING INSTRUCTIONS

All sizes adapters (backshell) of this configuration, must be filled with cement (potted).

The material exclusively certified for use in filling this connector is the bi-component epoxy resin supplied with connector.

WARNING

Do not use other cement than that supplied with connector.

Bulkhead adapter for panel mount receptacle should be filled to within about 1mm of the top. Potting flush with end of adapter is acceptable; care must be exercised so that the potting compound does not contaminate the bulkhead threads, or spill onto surfaces of the receptacle flange.

The goal is to have all the volume filled without interrupting the cable grommet from seating when the strain relief nut is installed.

Shell Size	36	28	16	14S	10SL
Min sealing height K [mm]	65	65	58	34	37

Potting/Cable adapter (backshell), filling depth

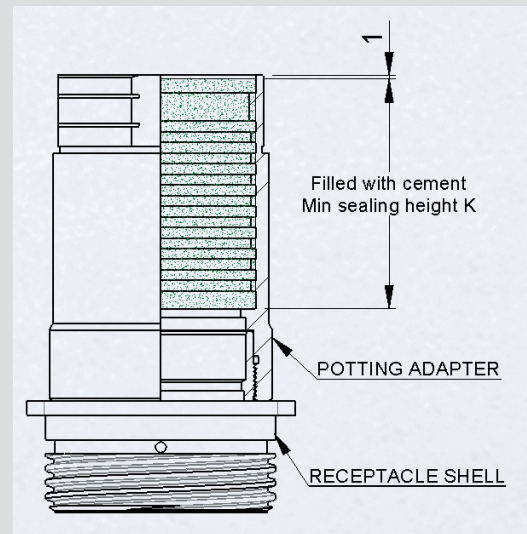

Verify the reached level of potting while curing to meet recommended end limits as shown in pictures above; potting is critical to assure explosion proof barrier.

The sealed length part of cable jacket and cores inside potting would be as follows.

Sealed length part of cable jacket / sheath and cores inside potting

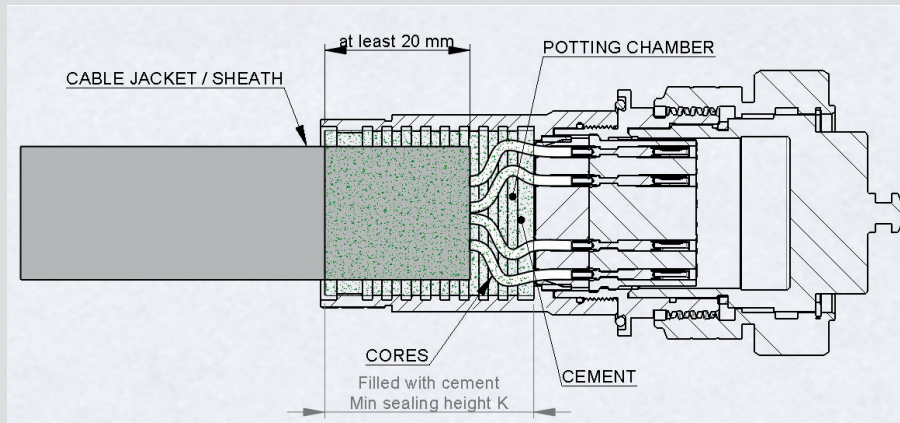

Potting materials and instructions

POTTING CHAMBER TO CONNECTOR ASSEMBLY

See ITS-Ex instruction manual D500500000 for In-Line and D500500002 for Panel Mount version, for best practice recommendations on connector termination, wiring, and assembly. Prior to completing potting step, properly assemble mechanical cable clamps, basket weave backshells, and cable glands to ITS-Ex series connectors follow these instructions.

1. Mount receptacle connector or plug body in an appropriate fixture such as a vice with smooth face or soft jaws (see illustration, right).
2. Apply thread locking compound (Loctite 242 blue or equivalent) to all backshell-to-connector threads.
3. Hand-tighten backshell accessory to connector.
4. Use a strap wrench or correctly sized flat wrench to tighten accessory fitting to connector according to torque values referenced in instruction manual D500500000 for In-Line and D500500002 for Panel Mount version (see illustration, right).

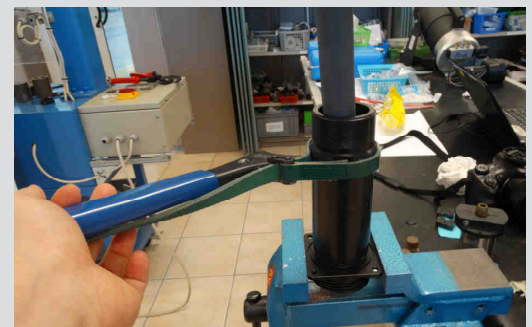

POTTING INSTRUCTIONS

1. Use only Glenair supplied 2-part epoxy resin for potting of ITS-Ex series connectors.
2. Fill potting chamber area behind wire terminations to the volume depths recommended in the illustrations and tables on opposite page. The goal is to fill as much of the potting area as required with material but to not inhibit the action and the performance of the cable sealing gland, follower, and clamp.
3. Glenair recommends when potting mated pairs of Series ITS-Ex connectors, always pot the connector with the female (socket) insert first. Once the socket side is set, backpot the male (pin) insert connector while mated with its corresponding pair. This will ensure correct axial alignment of the pin contacts in relation to socket contacts.
4. Throughout the potting process, the receptacle flange should be rigidly fixed in a vertical position as illustrated below. The fixture must be capable of holding the mated connector pair rigidly for a minimum of 4 hours at room temperature. The exiting conductor / cable should be fixed in line above the connector pair during the entire curing process.
5. Cut a corner of the cement flexible pack and completely fill a needle-equipped syringe applicator (for more information, please contact the factory).
6. Fill the potting chamber to the recommended depth, being careful to fill progressively from the wire grommet end towards the mouth of the backshell. Cement volume usage is approximated in the table below.



Shell Size	Approx. cement usage in a cable adapter
10SL	14.5 grams, about 0.50 ounces
14S	16 grams, about 0.56 ounces
16	50 grams, about 1.76 ounces
18	62.5 grams, about 2.20 ounces
28	110 grams, about 3.90 ounces
36	173 grams, about 6.10 ounces

SERIES 927-072 ITS-Ex Hazardous Zone Connectors



Panel Cut-outs

FIXED IN-LINE RECEPTACLE

Shell Size	ØA	B	Max Panel Thickness
10SL	27 ^{+0.5} ₀	33 ±0.1	49 ⁺¹ ₀
14S	29 ⁰ _{-0.5}	33 ±0.1	65 ⁺¹ ₀
16	35 ^{+0.5} ₀	39 ±0.1	74 ⁺¹ ₀
18	39 ^{+0.5} ₀	42 ±0.1	74 ⁺¹ ₀
28	55 ⁰ _{-0.5}	52 ±0.1	102 ⁺¹ ₀
36	64 ^{+0.5} ₀	62 ±0.1	120 ⁺¹ ₀

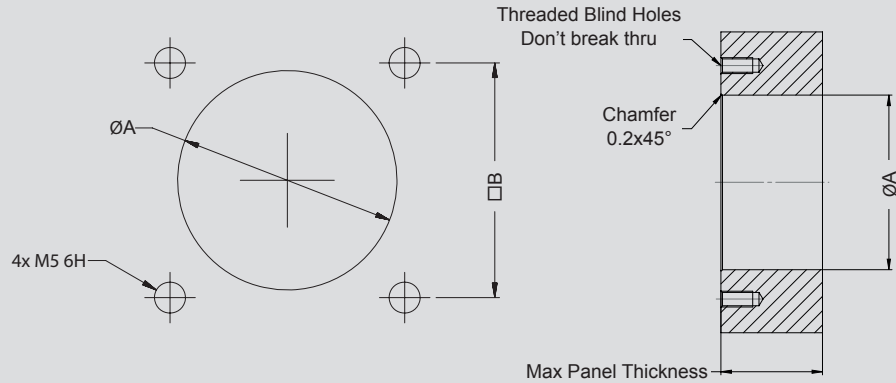

PANEL MOUNT FIXED RECEPTACLE Ex "d" (SCREW TYPE)

Shell Size	F Thread	B	Min Panel Thickness*
10SL	M25x1.5 6H	33 ±0.1	15 ^{+0.5} ₀
14S	M25x1.5 6H	33 ±0.1	15 ^{+0.5} ₀
16	M32x1.5 6H	39 ±0.1	15 ^{+0.5} ₀
28	M50x1.5 6H	52 ±0.1	15 ^{+0.5} ₀
36	M63x1.5 6H	62 ±0.1	15 ^{+0.5} ₀

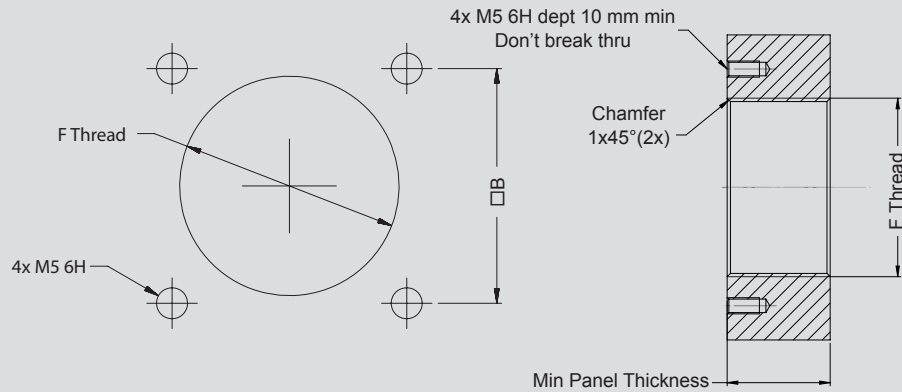

(*) For equipment screw type minimum panel thickness recommended is 7.5 mm

PANEL MOUNT FIXED RECEPTACLE Ex "e" (JAM NUT TYPE)

Shell Size	ØD	Max Panel Thickness
10SL	26 ±0.5	14 ±0.5
14S	26 ±0.5	14 ±0.5
16	33 ±0.5	14 ±0.5
28	51 ±0.5	14 ±0.5
36	64 ±0.5	14 ±0.5

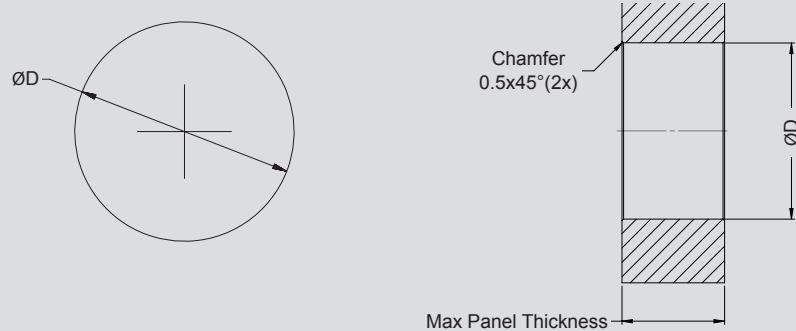

Electrical Performance

ELECTRICAL PARAMETERS

Voltage Service Rating IAW MIL-DTL-5015 (Specifications Non-Circuit Breaking)			
Service Voltage Rating	Operating Voltage VDC [V]	Operating Voltage VAC RMS [V]	Test Voltage VAC RMS [V]
I	250	200	1000
A	700	500	2000
D	1250	900	2800
E	1750	1250	3500
B	2450	1750	4500
C	4200	3000	7000

Contact Max Current Rating IAW NEC and VG95234 (Specifications Non-Circuit Breaking)					
Contact Size AWG	Wire Size AWG	Wire Size mm ²	Max Rated Current [A]		Max Resistance [mΩ]
			According to N.E.C. (1) (2)	According to VG95234 (1) (3)	
16-16S	22	0.25	3	3	6.0
	20	0.5	7.5	7.5	
	18	0.75-1	9	9	
	16	1.5	16	20	
12	16	1.5	16	20	3.0
	14-12	2.5	30	32	
8	12	4	30	32	1.0
	10	6	40	42	
	8	10	50	60	
4	8	10	50	60	0.5
	6	16	70	85	
	4	25	90	120	
0	1	50	132	190	0.3
	0	-	155	220	

(1) Apply derating per contact arrangement IAW MIL-W-5088L.

(2) Non-circuit breaking contacts rated current as per N.E.C. (National Electrical Code) based on arcing control. Use a cable of minimum rated temperature of 90°C.

(3) Values extrapolated from rated current chart of VG95234-1, at ambient temperature of 40°C. Use a cable of minimum rated temperature of 100°C.

Shell Size	Voltage Service Rating	Insert Arrangements	Contact Size AWG	Max Theoretical Rating Current per Shell Size (A)
10SL	A	2	16	48
14S	I, A	7	16	90
16	I, A, D, E	6	16-12-8-4	90
18	I, A, D, B, C	18	16-12-8-4	210
28	I, A, D, E, B	29	16-12-8-4-0	570
36	I, A, D, C	24	16-12-8-4-0	1110

WARNING

- Use suitable cable with minimum rated continuous operating temperature of 90°C with N.E.C. maximum rated current.
- Use suitable cable with minimum rated continuous operating temperature of 100°C with VG95234 maximum rated current.

As to derating per insert arrangement, when multiple conductors are used, the load factor and temperature rise based on ambient and total insert temperature must be taken into account.

MIL-W-5088 specifications shall be used as reference for derating per insert arrangement.



Contact arrangements

CONTACT ARRANGEMENTS BY SHELL SIZE

Shell Size	Contact Arrangement	Rating	Contact Number	Contact Size				
				0	4	8	12	16
10	10SL-3	A	3					3
	10SL-4	A	2					2
14S	14S-1	A	3					3
	14S-2	I	4					4
	14S-5	I	5					5
	14S-6	I	6					6
	14S-7	A	3					3
	14S-9	A	2					2
	14S-07	I	7					7
16	16-2	E	1				1	
	16-7	A	3		1			2
	16-9	A	4				2	2
	16-10	A	3				3	
	16-11	A	2				2	
	16-12	A	1		1			
18	18-1	I	10					10
	18-3	D	2				2	
	18-4	D	4					4
	18-5	D	3				2	1
	18-6	D	1		1			
	18-06	A	6				4	2
	18-7	B	1			1		
	18-8	A	8				1	7
	18-9	I	7				2	5
	18-10	A	4				4	
	18-11	A	5				5	
	18-12	A	6					6
	18-13	A	4			1	3	
	18-19	A	10					10
	18-20	A	5					5
18-22	D	3					3	
18-30 (18-20x110°)	A	5					5	
28	28-1	A	9			3	6	
	28-2	D	14				2	12
	28-3	E	3			3		
	28-6	D	3		3			
	28-09	A	9		4			5
	28-9	D	12				6	6
	28-10	A	7		2	2	3	
	28-11	A	22				4	18
	28-12	A	26					26
	28-13 (28-12x100°)	A	26					26
	28-15	A	35					35

Shell Size	Contact Arrangement	Rating	Contact Number	Contact Size				
				0	4	8	12	16
28	28-16	A	20					20
	28-17	A	15					15
	28-18	I	12					12
	28-19	A	10				4	6
	28-20	A	14				10	4
	28-21	A	37					37
	28-22	D	6		3			3
	28-51	D	12					12
	28-59	A	17				7	10
	28-70	A	7				7	
	28-84	A	9				9	
	28-124	A	16				4	12
	28-A29	A	29				2	27
	28-A35	A	35					35
	28-A63	I	28				9	19
	28-B1	B	1	1				
	28-B2	E	2				2	
	36	36-3	D	6	3			3
36-4		A	3	3				
36-5		A	4	4				
36-6		A	6	2	4			
36-7		A	47				7	40
36-8		A	47				1	46
36-9		A	31		1	2	14	14
36-10		A	48					48
36-14		D	16				5	5
36-15		A	35					35
36-18 (36-9x100°)		A	31		1	2	14	14
36-22		D	22					22
36-35		A	36				4	32
36-54=36-B39		A	39				8	31
36-66		A	56				4	52
36-74		A	44				1	43
36-77		D	7			7		
36-A7		A	7	3	2		2	
36-A35	A	8	4				4	
36-A51	D	6	3	2			1	
36-B78	D	14				12	2	
36-D78	D	14				10	4	

Contact arrangements by number of contacts

1 CONTACT

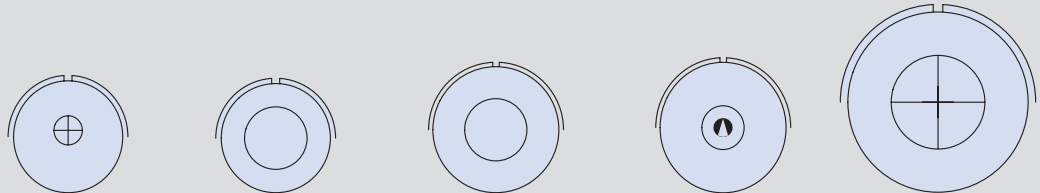

Arrangement	16-2	16-12	18-6	18-7	28B-1
Contact Size	12	4	4	8	0
Service Rating	E	A	D	B	B

2 CONTACTS

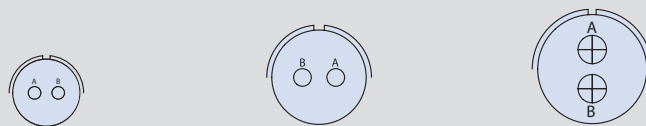

Arrangement	10SL-4	14S-9	16-11
Contact Size	16	16	12
Service Rating	A	A	A

2 CONTACTS

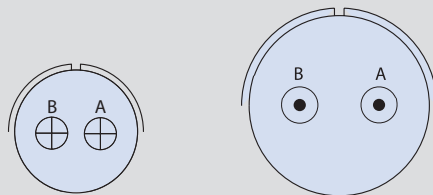

Arrangement	18-3	28-B2
Contact Size	12	8
Service Rating	D	E

3 CONTACTS

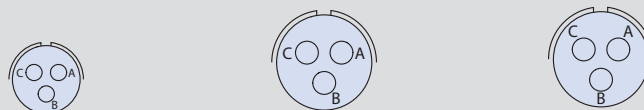

Arrangement	10SL-3	14S-1	14S-7
Contact Size	16	16	16
Service Rating	A	A	A

CONTACT LEGEND



Contact arrangements by number of contacts

3 CONTACTS

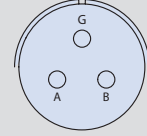
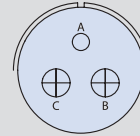
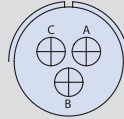
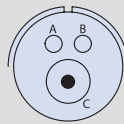

Arrangement	16-7	16-10	18-5	18-22
Contact Size	1/8, 2/16	12	2/12, 1/16	16
Service Rating	A	A	D	D

3 CONTACTS

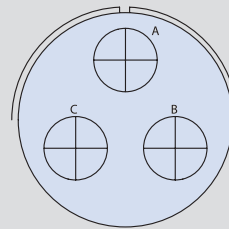
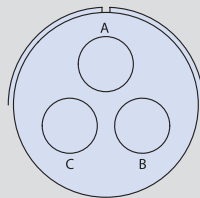
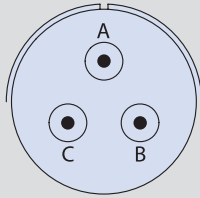

Arrangement	28-3	28-6	36-4
Contact Size	8	4	0
Service Rating	E	D	A=D; B,C=A

4 CONTACTS

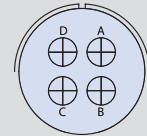
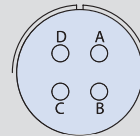
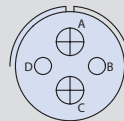
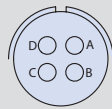

Arrangement	14S-2	16-9	18-4	18-10
Contact Size	16	2/12, 2/16	16	12
Service Rating	I	A	D	A

4 CONTACTS

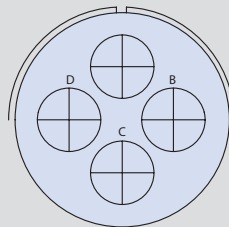
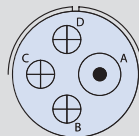

Arrangement	18-13	36-5
Contact Size	1/8, 3/12	0
Service Rating	A	A

CONTACT LEGEND



Contact arrangements by number of contacts

5 CONTACTS

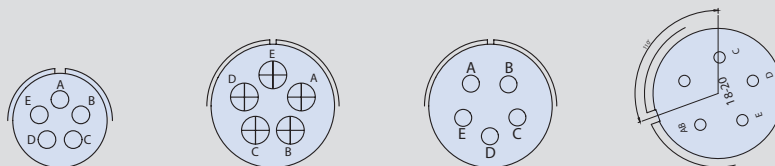

Arrangement	14S-5	18-11	18-20	18-30 (18-20 x 110°)
Contact Size	16	12	16	16
Service Rating	I	A	A	A

6 CONTACTS

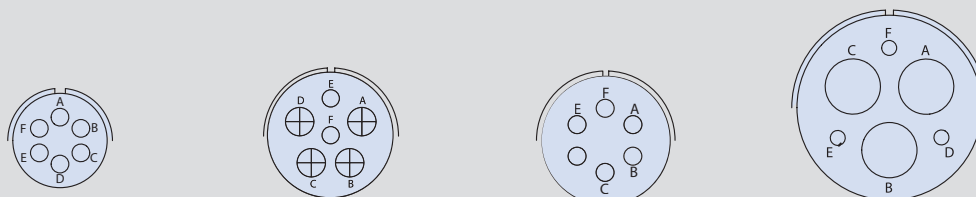

Arrangement	14S-6	18-06	18-12	28-22
Contact Size	16	4/12, 2/16	16	3/4, 3/16
Service Rating	I	A	A	D

6 CONTACTS

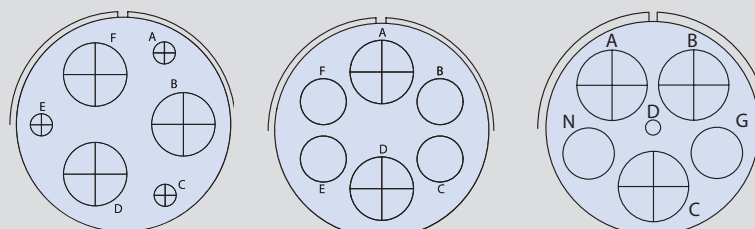

Arrangement	36-3	36-6	36A-51
Contact Size	3/0, 3/12	2/0, 4/4	3/0, 2/4, 1/16
Service Rating	D	A	D

7 CONTACTS

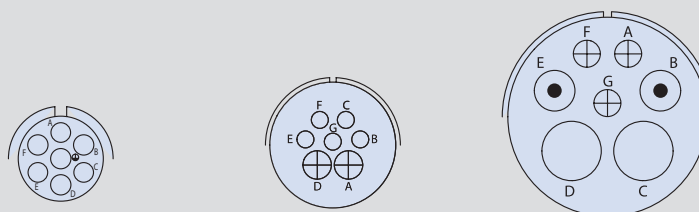

Arrangement	14S-07	18-9	28-10
Contact Size	16	2/12, 5/16	2/4, 2/8, 3/12
Service Rating	I	I	G=D; Bal=A

CONTACT LEGEND



Contact arrangements by number of contacts

7 CONTACTS

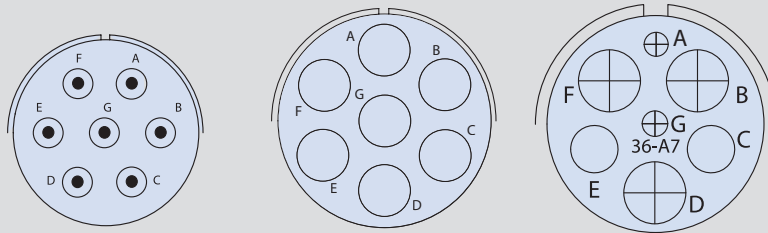

Arrangement	28-70	36-77	36-A7
Contact Size	8	4	3/0, 2/4, 2/12
Service Rating	A	D	A

8 CONTACTS

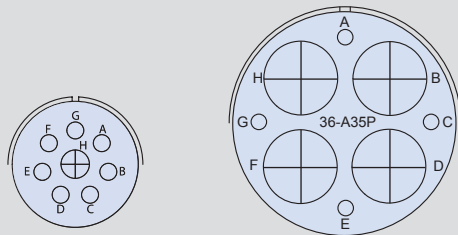

Arrangement	18-8	36-A35
Contact Size	1/12, 7/16	4/16, 4/0
Service Rating	A	A

9 CONTACTS

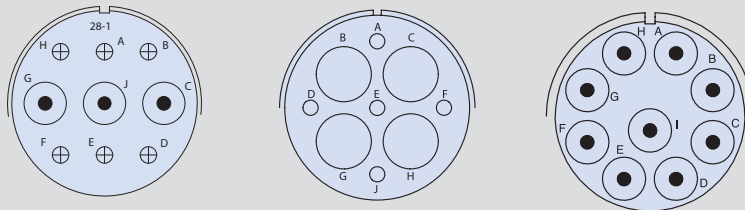

Arrangement	28-1	28-09	28-84
Contact Size	3/8, 6/12	4/4, 5/16	8
Service Rating	A, J, E=D; Bal=A	A	A

10 CONTACTS

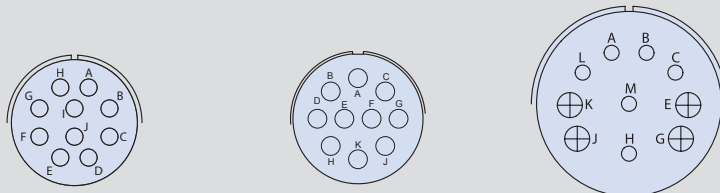

Arrangement	18-1	18-19	28-19
Contact Size	16	16	4/12, 6/16
Service Rating	B,C,F,G = A; Bal=I	A	A, B=D; K, M=B; Bal=A

CONTACT LEGEND



Contact arrangements by number of contacts

12 CONTACTS

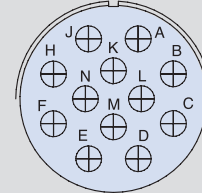
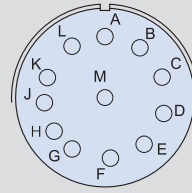
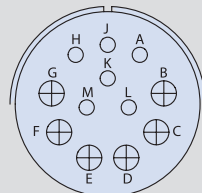

Arrangement	28-9	28-18	28-51
Contact Size	6/12, 6/16	16	12
Service Rating	D	A, B=A; G, H, J, K, L=D; M=C; Bal=I	D

14 CONTACTS

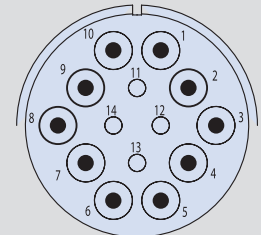
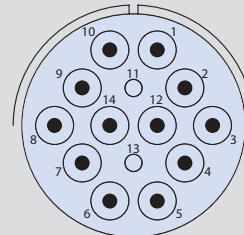
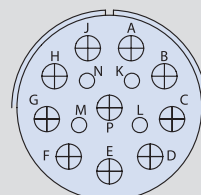
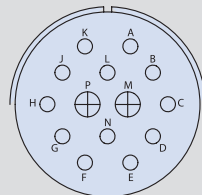

Arrangement	28-2	28-20	36-B78	36-D78
Contact Size	2/12, 12/16	10/12, 4/16	12/8, 2/16	10/8, 4/16
Service Rating	D	A	D	D

15 CONTACTS

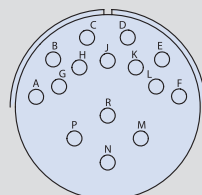

Arrangement	28-17
Contact Size	16
Service Rating	M, N, P=D; R=B; Bal=A

16 CONTACTS

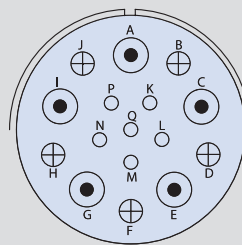
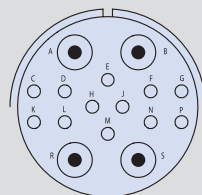

Arrangement	28-124	36-14
Contact Size	12/6, 4/8	5/8, 5/12, 6/16
Service Rating	A	D

CONTACT LEGEND	16	12	8	4	0
-----------------------	----	----	---	---	---

Contact arrangements by number of contacts

17 CONTACTS

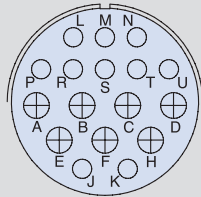

Arrangement	28-59
Contact Size	7/12, 10/16
Service Rating	A

20 CONTACTS

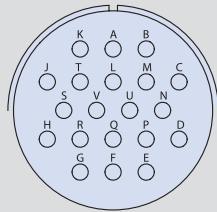

Arrangement	28-16
Contact Size	16
Service Rating	A

22 CONTACTS

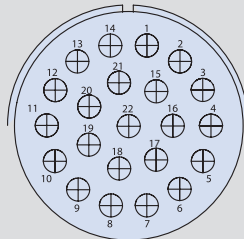
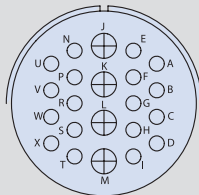

Arrangement	28-11	36-22
Contact Size	4/12, 18/16	12
Service Rating	A	D

26 CONTACTS

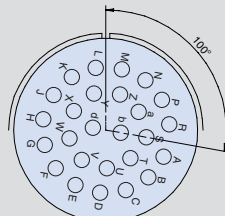
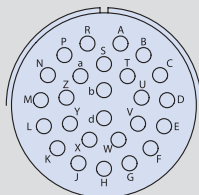

Arrangement	28-12	28-13 (28-12 x 100°)
Contact Size	16	16
Service Rating	A	A

CONTACT LEGEND



Contact arrangements by number of contacts

28 CONTACTS

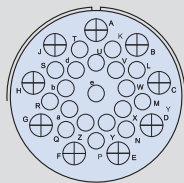

Arrangement	28-A63
Contact Size	9/12, 19/16
Service Rating	I

29 CONTACTS

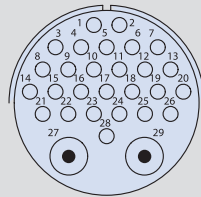

Arrangement	28-A29
Contact Size	2/8, 27/16
Service Rating	A

31 CONTACTS

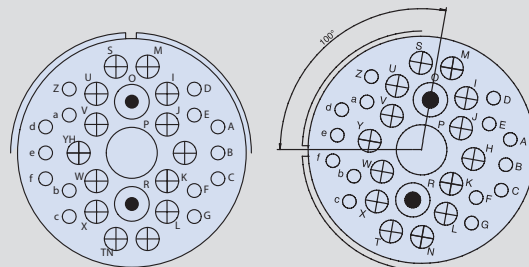

Arrangement	36-9	36-18 (36-9 x 100°)
Contact Size	1/4, 2/8, 14/12, 14/16	1/4, 2/8, 14/12, 14/16
Service Rating	A	A

35 CONTACTS

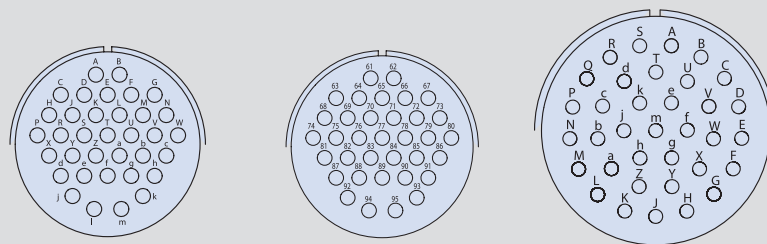

Arrangement	28-15	28-A35	36-15
Contact Size	16	16	16
Service Rating	A	A	M=D; Bal=A

CONTACT LEGEND					
----------------	--	--	--	--	--

Contact arrangements by number of contacts

36 CONTACTS

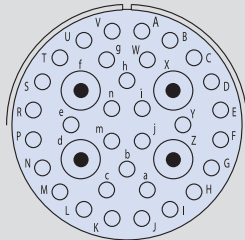

Arrangement	36-35
Contact Size	4/8, 32/16
Service Rating	A

37 CONTACTS

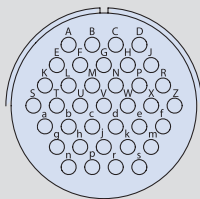

Arrangement	28-21
Contact Size	16
Service Rating	A

39 CONTACTS

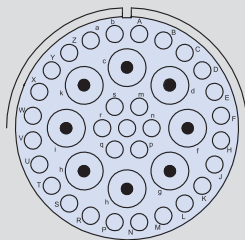

Arrangement	36-54 = 36-B39
Contact Size	8/8, 31/16
Service Rating	A

44 CONTACTS

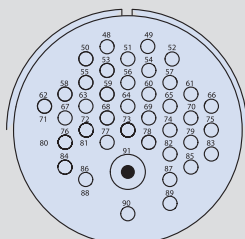

Arrangement	36-74
Contact Size	1/8, 43/16
Service Rating	A

CONTACT LEGEND



Contact arrangements by number of contacts

47 CONTACTS

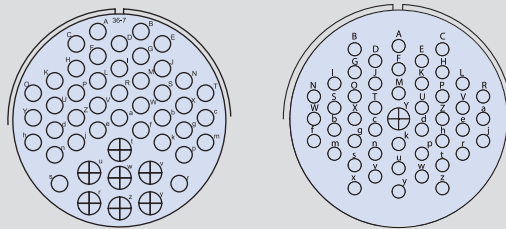

Arrangement	36-7	36-8
Contact Size	7/12, 40/16	1/12, 46/16
Service Rating	A	A

48 CONTACTS

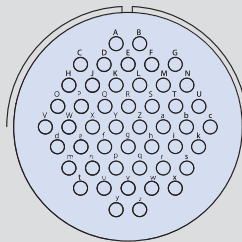

Arrangement	36-10
Contact Size	16
Service Rating	A

56 CONTACTS

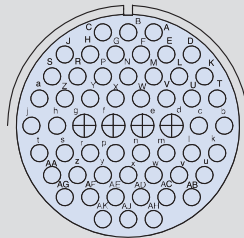

Arrangement	36-66
Contact Size	4/12, 52/16
Service Rating	A

CONTACT LEGEND

Contact arrangements by number of contacts

INSERT ROTATION ALTERNATE POSITIONS

Arrangement	$\alpha \pm 2^\circ$			
	W	X	Y	Z
10SL-3				
10SL-4				
14S-1	90	180	270	
14S-2		120	240	
14S-5		110		
14S-6	90			
14S-7	90	180	270	
14S-9	70	145	215	290
14S-07				
16-2				
16-7	80	110	250	280
16-9	35	110	250	325
16-10	90	180	270	
16-11	35	110	250	325
16-12				
18-1	70	145	215	290
18-3	35	110	250	325
18-4	35	110	250	325
18-5	80	110	250	280
18-6				
18-06	180			
18-7				
18-8	70			290
18-9	80	110	250	280
18-10		120	240	
18-11		170	265	
18-12	80			280
18-13	80	110	250	280
18-19		120	240	
18-20	90	180	270	
18-22	70	145	215	290
18-30				

Arrangement	$\alpha \pm 2^\circ$			
	W	X	Y	Z
28-1	80	110	250	280
28-2	35	110	250	325
28-3	70	145	215	290
28-6	70	145	215	290
28-09	110	250	260	280
28-9	80	110	250	280
28-10	80	110	250	280
28-11	80	110	250	280
28-12	90	180	270	
28-13				
28-15	80	110	250	280
28-16	80	110	250	280
28-17	80	110	250	280
28-18	70	145	215	290
28-19	80	110	250	280
28-20	80	110	250	280
28-21	80	110	250	280
28-22	70	145	215	290
28-51	80	135	190	
28-59	35	110	250	325
28-70	80			280
28-84	45	157	90	135
28-124	80	110	250	280
28A-29	80	110	250	280
28A-35	80	110	250	280
28A-63		100	260	
28-B1				
28-B2				

Arrangement	$\alpha \pm 2^\circ$			
	W	X	Y	Z
36-3	70	145	215	290
36-4	70	145	215	290
36-5		120	240	
36-6	35	110	250	325
36-7	80	110	250	280
36-8	80	110	250	280
36-9	80	125	235	280
36-10	80	125	235	280
36-14	90	180	270	
36-15	60	125	245	305
36-18				
36-22	80	110	250	280
36-35				
36-54 = 36-B39	67			
36-66	110	250	260	280
36-74				
36-77	45	90		
36-A7				
36-A35				
36-A51	45	135	225	315
36B-78	35	106	254	325
36D-78	35	106	254	325

Insert Rotation (front view)

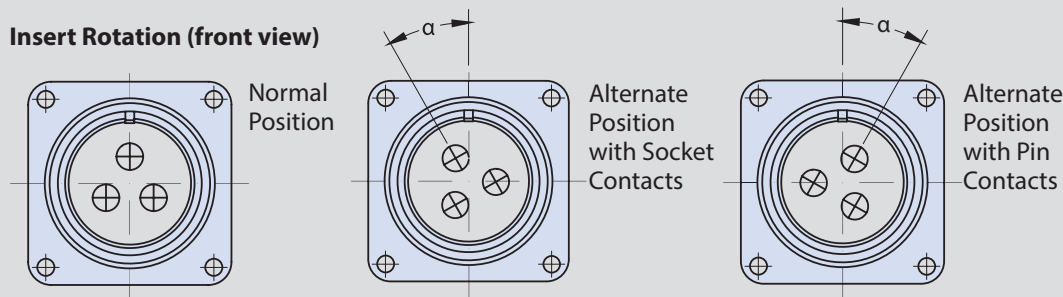



SERIES ITS-Ex

Industrial-strength power and signal connector series qualified for use in hazardous zone interconnect applications



Designed for safe operation in petrochemical refineries, oil & gas drilling platforms, and other explosion zone applications, the Glenair ITS-Ex series connector is optimized for life-of-system durability and reliability. Qualified by the globally-recognized IEC and IECEx standards bodies, the connector series is suitable for use in application areas where flammable gases and vapors are present as a normal condition of operation (group IIC) and with temperature classes T6 and T5, zones 1 and 2; and for applications where potentially flammable dust is present as a normal condition of operation (group IIIC) and with temperature classes T80°C and T95°C in zone 21 and 22.

Series ITS-Ex is designed for easy and repeatable termination of armored and unarmored cables built to IEEE 45, IEC, BS, DIN, and JIC standards. A full range of power and signal contacts, from size #16 to size #0 in over 40 insert arrangements are available to address all common voltage, wire size and connector service class ratings.

Special Ex design attributes of the series include an integral labyrinth flame path cooling zone, 2-part epoxy potting well, fixed in-line receptacles for attachment of cables to cable management brackets and trays, set screw (grub screw) secured protective safety covers, and durable life-of-system Ex marking labels.

APPLICATION AND INSTALLATION

- Glenair assembly procedure D500500000 for In-Line and D500500002 for Panel Mount version to be referenced for certified operator assembly
- Always use Loctite 242 or equivalent (medium strength threadlocker) on all threaded joints
- All set screws (grub screws) must be fully tightened during installation and operation

Series ITS-Ex Hazardous Zone Connectors

Product Selection Guide

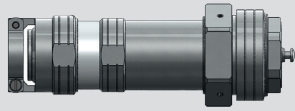

927-072-016

Plug with Mechanical Clamp

Page 36

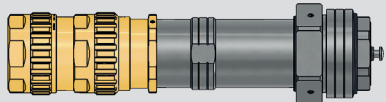

927-072-026

Plug with Ex d Cable Gland

Page 38

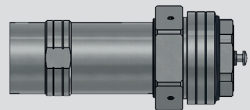

927-072-026

Plug for Ex d Cable Gland

Page 40

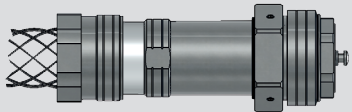

927-072-036

Plug with Basket Weave Cable Grip

Page 42



927-072-012

Fixed In-Line Receptacle with Mechanical Clamp

Page 44

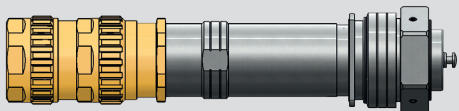

927-072-022

Fixed In-Line Receptacle with Ex d Cable Gland

Page 46

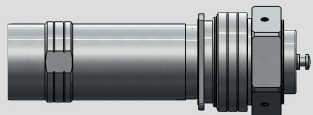

927-072-022

Fixed In-Line Receptacle for Ex d Cable Gland

Page 48

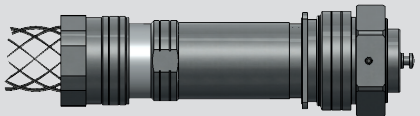

927-072-032

Fixed In-Line Receptacle with Basket Weave Cable Grip

Page 50



927-072-011

In-Line Receptacle with Mechanical Clamp

Page 52

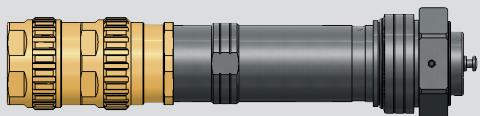

927-072-021

In-Line Receptacle with Ex d Cable Gland

Page 54

Product Selection Guide

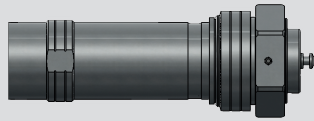

927-072-021

In-Line Receptacle for Ex d Cable Gland

Page 56

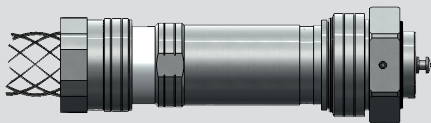

927-072-031

In-Line Receptacle with Basket Weave Cable Grip

Page 58

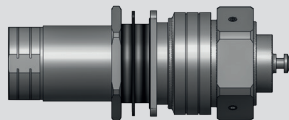

927-072-003

Panel Mount Fixed Receptacle

Page 60

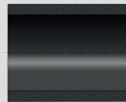

Reduction Sleeve

Spare reduction sleeves for small cable diameters

Page 62



Contacts

Pin and Socket Crimp Contacts

Page 63



Wire Hole Plugs

For Contacts Inserts and Wire Sealing Grommets

Page 67



Contact Tools

Crimp, Insertion and Removal Tools

Page 69

Hazardous Zone Plug

with mechanical cable clamp



927-072-016 PLUG WITH ENVIRONMENTAL CABLE ADAPTER AND MECHANICAL CABLE CLAMP

How To Order							
Sample Part Number	927-072	-016	-36-66	P1	F9	Y	/A
Series	927-072						
Style	-016 = Mechanical Cable Clamp						
Shell Size - Insert Arrangement	See pages 22- 31						
Contact Type and Plating	P = Pin Contact, S = Socket Contact 1 = Silver Plated, 2 = Gold Plated						
Shell Material and Finish	F9 = Aluminium Alloy, Anodize Hardcoat						
Alternate Key Position	X, Y, Z, W (See Table on page 32) Omit for normal position						
Cable Range	A, B, C (See Table next page)						

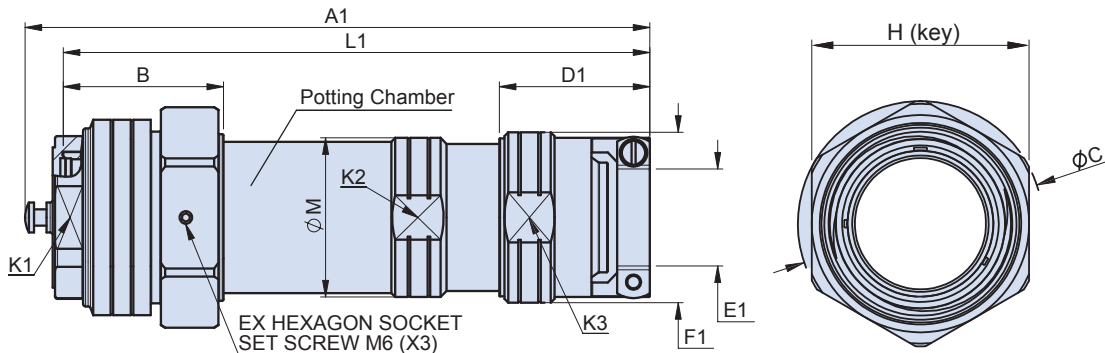

Shell Size	Dimensions												
	A1	B	C	D1	E1		F1	H	K1	K2	K3	L1	M
					Min.	Max.							
10SL	146	55.6	46	40.7	4.50	11.12	28.0	41	24	22	27	132	25
14S	*	*	*	*	*	*	*	*	*	*	*	*	*
16	184	63.9	54	42.8	8.0	19.0	40.0	49	30	32	38	169	34
18	185	63.9	59	45.2	9.60	23.80	43.0	52	34	36	41	170	38.2
28	226	63.9	72	56.7	15.5	35.0	62.0	65	48	48	60	211	54
36	250	63.9	88	60	23.40	41.25	68.0	78	60	61	65	235	63.5

(*) Please contact the factory.

Left view

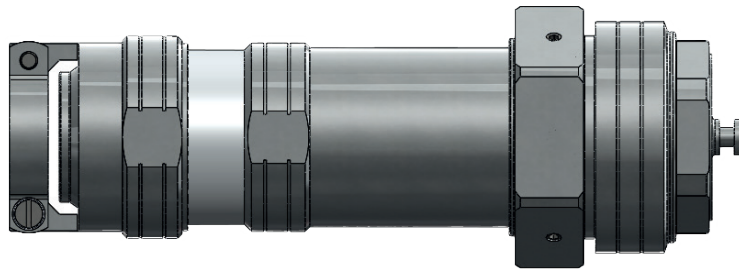

Front view

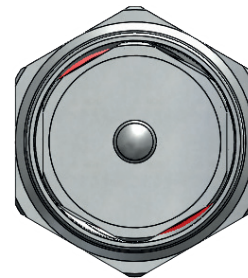

Section view

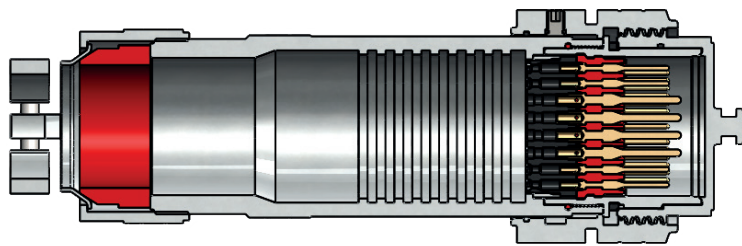

Front view without cap

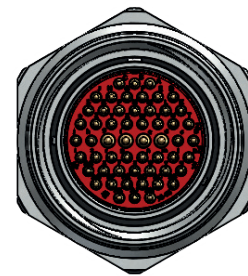

Cable Range Dimensions for Mechanical Cable Clamp			
Shell Size	Cable Type (1)	Cable Range Designator	Cable Jacket Range [mm] (2)
36	Unarmored cable	A	29,90 to 41,25
		B	23,40 to 35,00
28	Unarmored cable	A	28,50 to 35,00
		B	23,40 to 31,75
		C	15,50 to 23,80
18	Unarmored cable	A	15,50 to 23,80
		B	11,30 to 19,00
		C	9,60 to 15,90
16	Unarmored cable	A	11,30 to 19,00
		B	9,60 to 15,87
		C	8,00 to 13,48
10SL	Unarmored cable	A	5,84 to 11,12
		B	4,50 to 7,93

(1) Armoured cables may be used but the armour cannot be engaged.

(2) It is advisable to use reduction sleeves for lower values of cable diameter within cable range.

SERIES 927-072
Hazardous Zone Plug
 with Ex cable gland



927-072-026 PLUG WITH ENVIRONMENTAL CABLE ADAPTER AND EX CABLE GLAND

How To Order							
Sample Part Number	927-072	-026	-36-66	P1	F9	Y	/A
Series	927-072						
Style	-026 = Ex Cable Gland						
Shell Size - Insert Arrangement	See pages 22- 31						
Contact Type and Plating	P = Pin Contact, S = Socket Contact 1 = Silver Plated, 2 = Gold Plated						
Shell Material and Finish	F9 = Aluminium Alloy, Anodize Hardcoat						
Alternate Key Position	X, Y, Z, W (See Table on page 32) Omit for normal position						
Cable Range	A, B, C (See Table next page)						

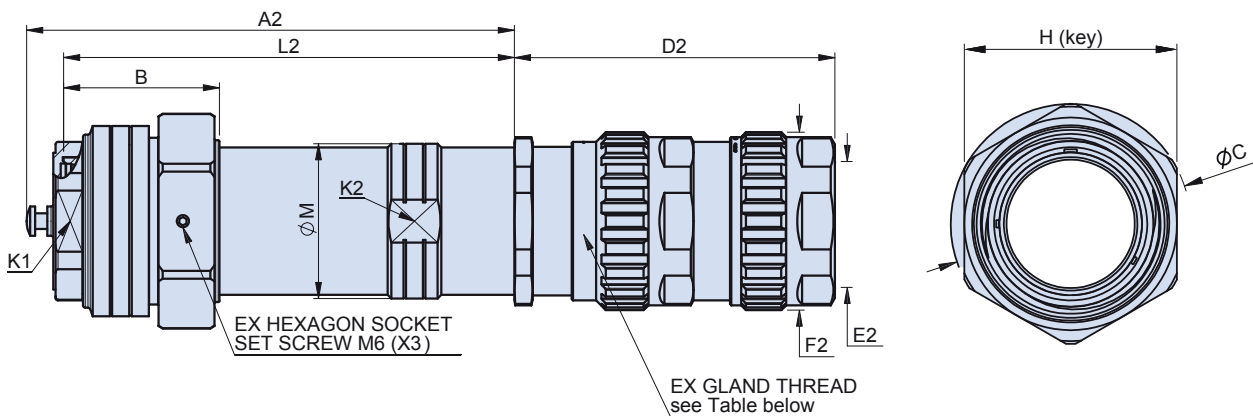

Shell Size	Dimensions												
	A2	B	C	D2	E2		Backshell Thread for Ex Gland	F2	H	K1	K2	L2	M
10SL	105	55.6	46	*	6.0	20.50	M20x1.5 M16x1.5	*	41	24	24	91	25
14S	128	55.6	49	*	6.0	20.50	M20x1.5 M16x1.5	*	45	27	26	111	28
16	150	63.9	54	*	6.0	20.50	M20x1.5 M16x1.5	*	49	30	32	135	34
18	151	63.9	59	*	6.0	26.0	M25x1.5 M20x1.5 M16x1.5	*	52	34	36	135	38.2
28	180	63.9	72	*	16.9	41.0	M40x1.5 M32x1.5 M25x1.5 M20x1.5 M16x1.5	*	65	48	48	165	54
36	201	63.9	88	*	22.0	52.60	M50x1.5 M40x1.5 M32x1.5 M25x1.5 M20x1.5 M16x1.5	*	78	60	61	185	63.5

(*) Dimension varies according to Ex Cable Gland.



Cable Range Dimensions for Ex Cable Gland						
Shell Size	Cable Range Designator	Cable Type	Ex Gland Thread	Cable outer sheath range [mm]	Cable inner sheath range [mm]	Armor Range with Clamping Ring
36	A	Unarmored cable	M50x1.5	28 to 41		
	B		M40x1.5	22 to 33		
	C		M32x1.5	16,90 to 26		
	D		M25x1.5	12,50 to 20,50		
	E		M20x1.5	9 to 16		
	F		M20x1.5	6 to 12		
	G		M16x1.5	6 to 12		
	A1	Armored Cable	M50x1.5	36 to 52,60	28,90 to 44,40	0 to 1,0 and 1,5 to 2,5
	B1		M40x1.5	28 to 41	22 to 33	0 to 0,7 and 1,3 to 2,0
	C1		M32x1.5	22 to 33		0 to 0,7 and 1,3 to 2,0
	D1		M25x1.5	16,90 to 26		0 to 0,7 and 0,9 to 1,6
	E1		M25x1.5	12,50 to 20,50		0 to 0,7 and 0,7 to 1,4
	F1		M20x1.5	12,50 to 20,50		0 to 0,7 and 0,7 to 1,4
	G1		M20x1.5	9 to 16		0 to 0,7 and 0,7 to 1,25
H1	M20x1.5	6 to 12		0 to 0,7 and 0,7 to 1,25		
I1	M16x1.5	6 to 12		0 to 0,7 and 0,7 to 1,25		
28	A	Unarmored cable	M40x1.5	22 to 33		
	B		M32x1.5	16,90 to 26		
	C		M25x1.5	12,50 to 20,50		
	D		M20x1.5	9 to 16		
	E		M20x1.5	6 to 12		
	F		M16x1.5	6 to 12		
	A1	Armored Cable	M40x1.5	28 to 41	22 to 33	0 to 0,7 and 1,3 to 2,0
	B1		M32x1.5	22 to 33	16,90 to 26	0 to 0,7 and 1,3 to 2,0
	C1		M25x1.5	16,90 to 26	12,50 to 20,50	0 to 0,7 and 0,9 to 1,6
	D1		M25x1.5	12,50 to 20,50	9 to 14	0 to 0,7 and 0,7 to 1,4
	E1		M20x1.5	12,50 to 20,50	9 to 14	0 to 0,7 and 0,7 to 1,4
	F1		M20x1.5	9 to 16	6 to 12	0 to 0,7 and 0,7 to 1,25
	G1		M20x1.5	6 to 12	3 to 8,1	0 to 0,7 and 0,7 to 1,25
	H1		M16x1.5	6 to 12	3 to 8,1	0 to 0,7 and 0,7 to 1,25
18	A	Unarmored cable	M25x1.5	12,50 to 20,50		
	B		M20x1.5	9 to 16		
	C		M20x1.5	6 to 12		
	D		M16x1.5	6 to 12		
	A1	Armored Cable	M25x1.5	16,90 to 26	12,50 to 20,50	0 to 0,7 and 0,9 to 1,6
	B1		M25x1.5	12,50 to 20,50	9 to 14	0 to 0,7 and 0,7 to 1,4
	C1		M20x1.5	12,50 to 20,50	9 to 14	0 to 0,7 and 0,7 to 1,4
	D1		M20x1.5	9 to 16	6 to 12	0 to 0,7 and 0,7 to 1,25
	E1		M20x1.5	6 to 12	3 to 8,1	0 to 0,7 and 0,7 to 1,25
	F1		M16x1.5	6 to 12	3 to 8,1	0 to 0,7 and 0,7 to 1,25
16 14S 10SL	A	Unarmored cable	M20x1.5	9 to 16		
	B		M20x1.5	6 to 12		
	C		M16x1.5	6 to 12		
	A1	Armored Cable	M20x1.5	12,50 to 20,50	9 to 14	0 to 0,7 and 0,7 to 1,4
	B1		M20x1.5	9 to 16	6 to 12	0 to 0,7 and 0,7 to 1,25
	C1		M20x1.5	6 to 12	3 to 8,1	0 to 0,7 and 0,7 to 1,25
	D1		M16x1.5	6 to 12	3 to 8,1	0 to 0,7 and 0,7 to 1,25

SERIES 927-072
Hazardous Zone Plug
 for Ex cable gland



927-072-026 PLUG WITH ENVIRONMENTAL CABLE ADAPTER FOR EX CABLE GLAND

How To Order							
Sample Part Number	927-072	-026	-36-66	P1	F9	Y	/A0
Series	927-072						
Style	-026 = Ex Cable Gland						
Shell Size - Insert Arrangement	See pages 22- 31						
Contact Type and Plating	P = Pin Contact, S = Socket Contact 1 = Silver Plated, 2 = Gold Plated						
Shell Material and Finish	F9 = Aluminium Alloy, Anodize Hardcoat						
Alternate Key Position	X, Y, Z, W (See Table on page 32) Omit for normal position						
Cable Range	A0, B0, C0 (See Table next page) Ex Cable Gland not supplied						

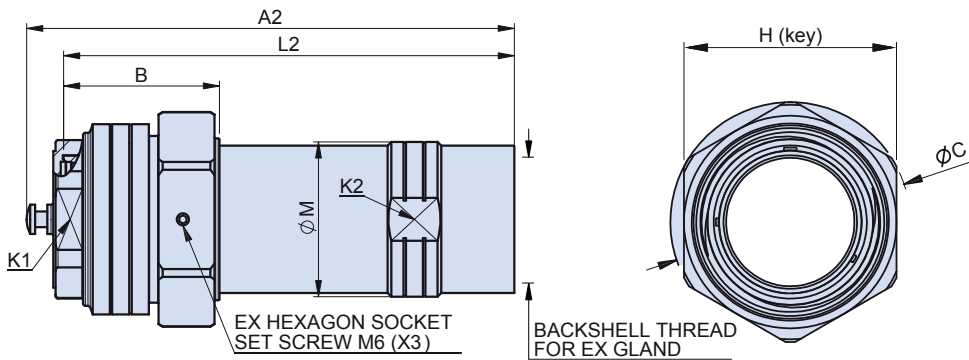

Dimensions									
Shell Size	A2	B	C	Backshell Thread for Ex Gland	H	K1	K2	L2	M
10SL	105	55.6	46	M20x1.5 M16x1.5	41	24	24	91	25
14S	128	55.6	49	M20x1.5 M16x1.5	45	27	26	111	28
16	150	63.9	54	M20x1.5 M16x1.5	49	30	32	135	34
18	151	63.9	59	M25x1.5 M20x1.5 M16x1.5	52	34	36	135	38.2
28	180	63.9	72	M40x1.5 M32x1.5 M25x1.5 M20x1.5 M16x1.5	65	48	48	165	54
36	201	63.9	88	M50x1.5 M40x1.5 M32x1.5 M25x1.5 M20x1.5 M16x1.5	78	60	61	185	63.5

SERIES 927-072
Hazardous Zone Plug
 for Ex cable gland

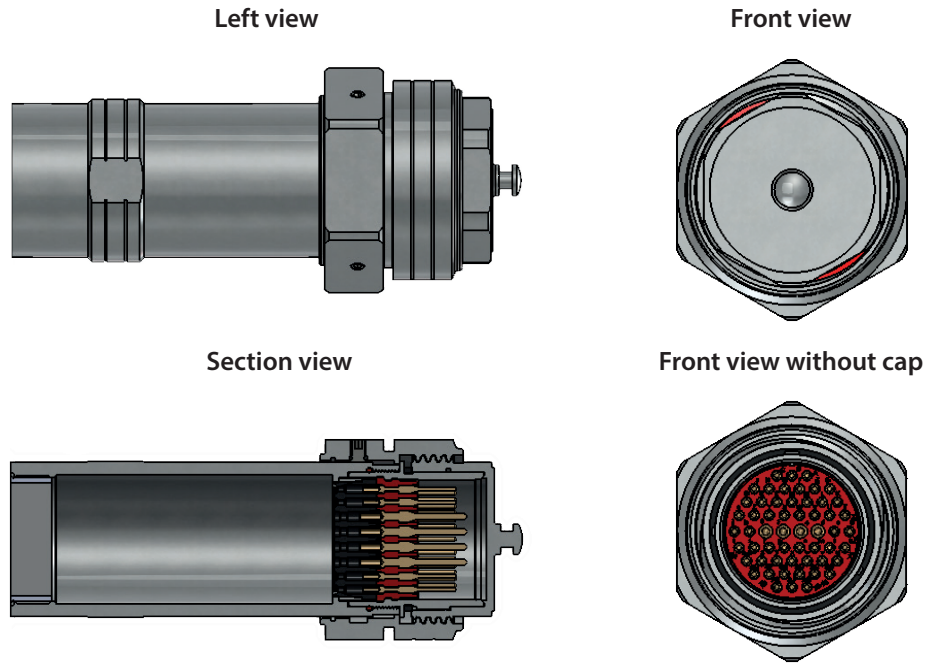

Cable Range Dimensions for Ex Cable Gland			
Shell Size	Cable Type	Cable Range Designator	Backshell Thread for Ex Gland
36	Armored/ Unarmored cable	A0	M50x1.5
		B0	M40x1.5
		C0	M32x1.5
		D0	M25x1.5
		E0	M20x1.5
		F0	M16x1.5
28	Armored/ Unarmored cable	A0	M40x1.5
		B0	M32x1.5
		C0	M25x1.5
		D0	M20x1.5
		E0	M16x1.5
18	Armored/ Unarmored cable	A0	M25x1.5
		B0	M20x1.5
		C0	M16x1.5
16 14S 10SL	Armored/ Unarmored cable	A0	M20x1.5
		B0	M16x1.5

927-072-036 PLUG WITH ENVIRONMENTAL CABLE ADAPTER AND BASKET WEAVE CABLE GRIP

How To Order							
Sample Part Number	927-072	-036	-36-66	P1	F9	Y	/A
Series	927-072						
Style	-036 = Basket Weave Cable Grip						
Shell Size - Insert Arrangement	See pages 22- 31						
Contact Type and Plating	P = Pin Contact, S = Socket Contact 1 = Silver Plated, 2 = Gold Plated						
Shell Material and Finish	F9 = Aluminium Alloy, Anodize Hardcoat						
Alternate Key Position	X, Y, Z, W (See Table on page 32) Omit for normal position						
Cable Range	A, B, C (See Table next page)						

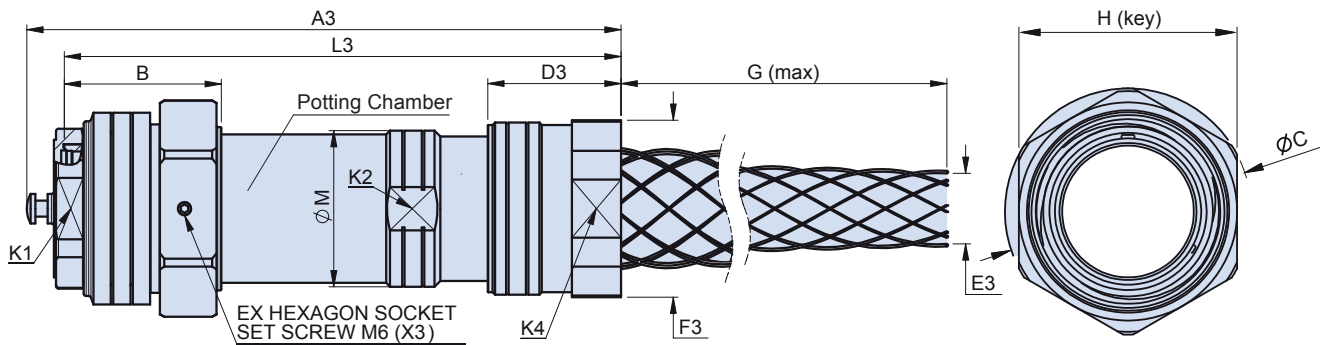

Shell Size	Dimensions													
	A3	B	C	D3	E3		F3	G Max.	H	K1	K2	K4	L3	M
					Min.	Max.								
10SL	*	*	*	*	*	*	*	*	*	*	*	*	*	*
14S	*	*	*	*	*	*	*	*	*	*	*	*	*	*
16	159	63.9	54	35.5	8.0	19.0	42.0	179**	49	30	32	38	143	34.0
18	182	63.9	59	42.7	10.40	23.80	46.0	201**	52	34	36	42	177	38.2
28	224	63.9	72	54.2	17.5	34.1	64.0	239**	65	48	48	60	209	54.0
36	242	63.9	88	52.4	25.60	41.25	72.0	315**	78	60	61	68	227	63.5

(*) Please contact the factory.

(**) Max overall dimension; dimension less than max one, depending on Basket Weave Cable Range.

Hazardous Zone Plug

with basket weave cable grip

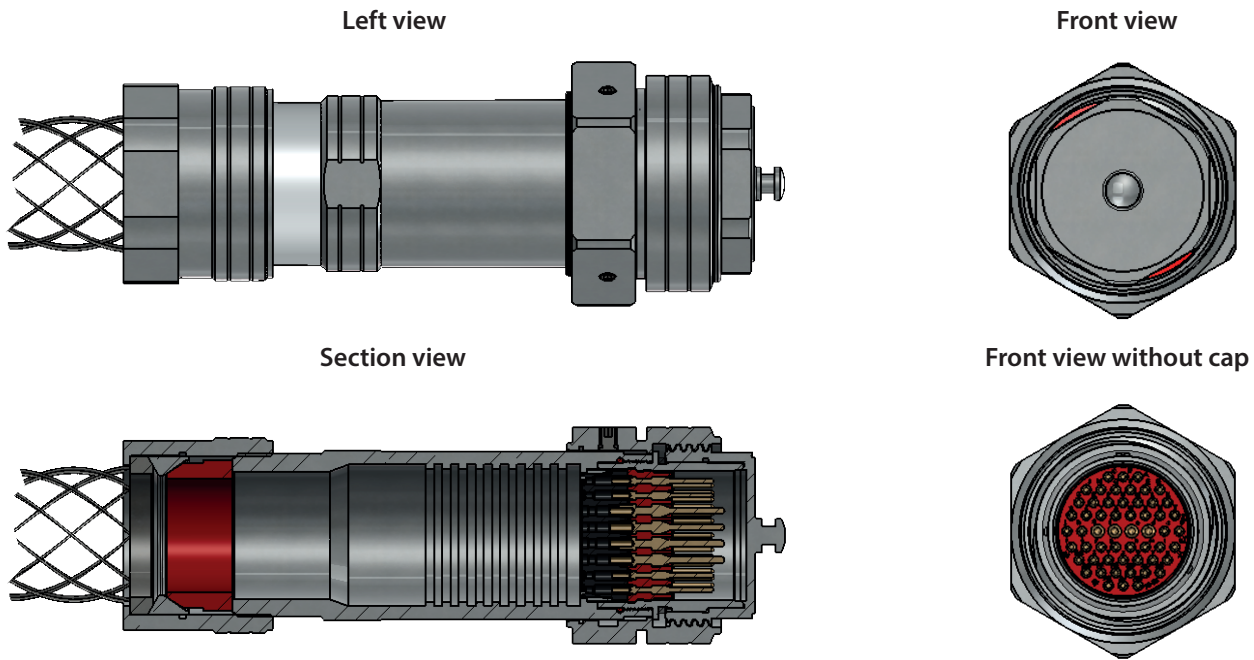

Cable Range Dimensions for Basketweave Cable Grip			
Shell Size	Cable Type (1)	Cable Range Designator	Cable Jacket Range [mm] (2)
36	Unarmored cable	A	39,40 to 41,25
		B	38,90 to 40,50
		C	34,50 to 38,50
		D	31,00 to 34,90
		E	29,40 to 33,30
		F	25,60 to 29,50 (1)
28	Unarmored cable	A	30,10 to 34,10
		B	28,50 to 32,00
		C	25,50 to 29,10
		D	23,40 to 26,60 (1)
		E	21,10 to 23,80
		F	17,50 to 21,40 (1)
18	Unarmored cable	A	19,60 to 23,80
		B	18,00 to 22,20 (1)
		C	15,50 to 19,00
		D	12,70 to 15,90
		E	10,40 to 12,70 (1)
16	Unarmored cable	A	15,50 to 19,00
		B	12,70 to 15,90 (1)
		C	10,40 to 12,70 (1)
		D	8,00 to 9,50 (1)

(1) Armoured cables may be used but the armour cannot be engaged.

(2) It is advisable to use reduction sleeves for lower values of cable diameter within cable range.

Hazardous Zone Fixed In-Line Receptacle with mechanical cable clamp



927-072-012 FIXED IN-LINE RECEPTACLE WITH ENVIRONMENTAL CABLE ADAPTER AND MECHANICAL CABLE CLAMP

How To Order							
Sample Part Number	927-072	-012	-36-66	P1	F9	Y	/A
Series	927-072						
Style	-012 = Mechanical Cable Clamp						
Shell Size - Insert Arrangement	See pages 22- 31						
Contact Type and Plating	P = Pin Contact, S = Socket Contact 1 = Silver Plated, 2 = Gold Plated						
Shell Material and Finish	F9 = Aluminium Alloy, Anodize Hardcoat						
Alternate Key Position	X, Y, Z, W (See Table on page 32) Omit for normal position						
Cable Range	A, B, C (See Table next page)						

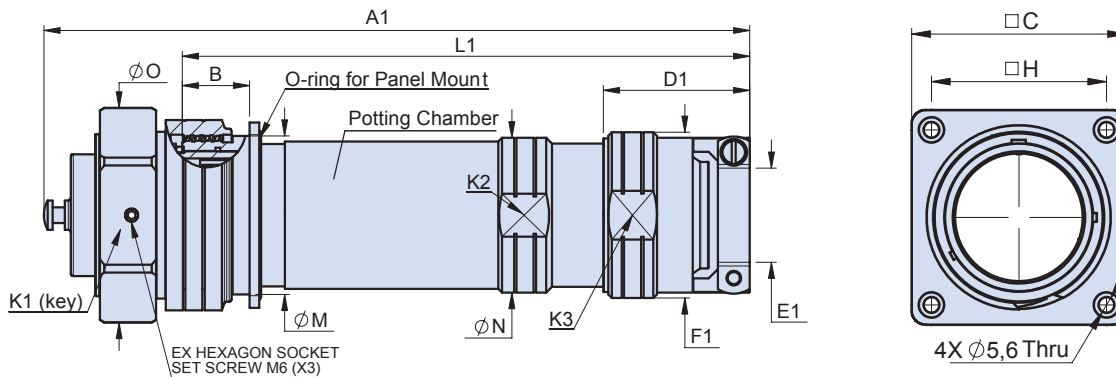

Shell Size	Dimensions														
	A1	B	C	D1	E1		F1	H ± 0.1	K1	K2	K3	L1	M	N	O
					Min.	Max.									
10SL	179	24.7	45	40.7	4.50	11.12	28.0	33	41	22	27	130	26	25	46
14S	*	*	*	*	*	*	*	*	*	*	*	*	*	*	*
16	224	27.5	51	42.8	8.0	19.0	40.0	39	49	32	38	167	34	34.0	54
18	225	27.6	57	45.2	9.60	23.80	43.0	42	52	36	41	170	38	38.2	59
28	266	27.6	67	56.7	15.50	35.0	62.0	52	65	48	60	210	52	54	72
36	290	27.6	76	60	23.40	41.25	68.0	62	78	61	65	233	65	63.5	88

(*) Please contact the factory.

Hazardous Zone Fixed In-Line Receptacle with mechanical cable clamp

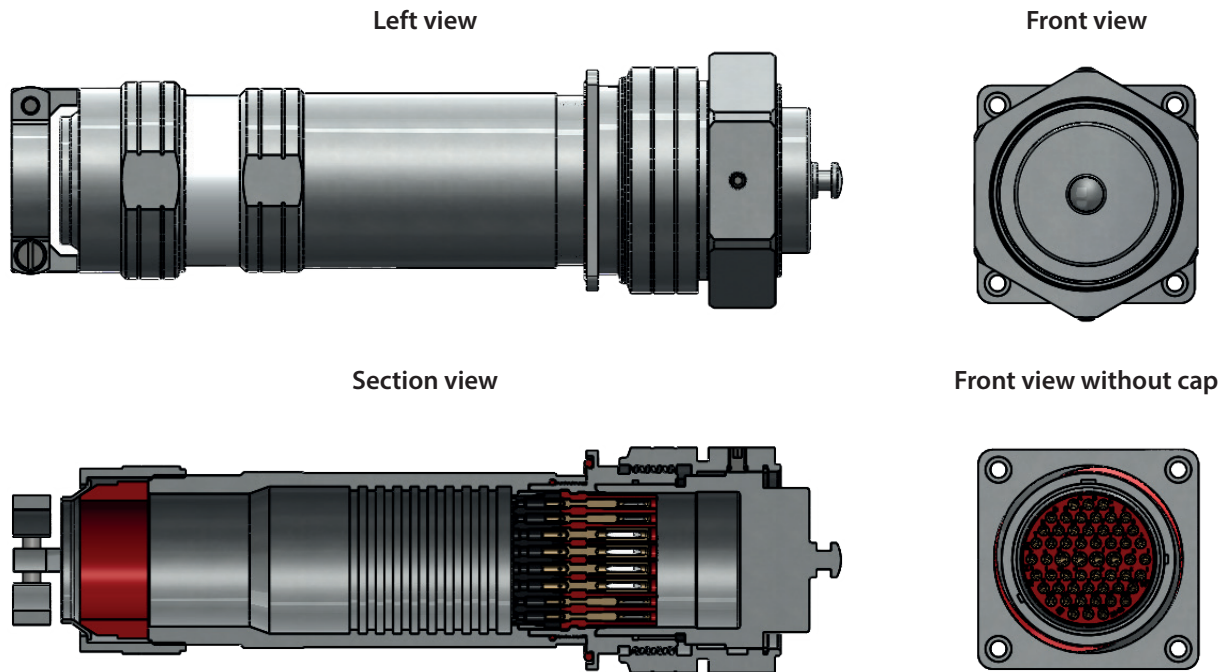

Cable Range Dimensions for Mechanical Cable Clamp			
Shell Size	Cable Type (1)	Cable Range Designator	Cable Jacket Range [mm] (2)
36	Unarmored cable	A	29,90 to 41,25
		B	23,40 to 35,00
28	Unarmored cable	A	28,50 to 35,00
		B	23,40 to 31,75
		C	15,50 to 23,80
18	Unarmored cable	A	15,50 to 23,80
		B	11,30 to 19,00
		C	9,60 to 15,90
16	Unarmored cable	A	11,30 to 19,00
		B	9,60 to 15,87
		C	8,00 to 13,48
10SL	Unarmored cable	A	5,84 to 11,12
		B	4,50 to 7,93

(1) Armoured cables may be used but the armour cannot be engaged.

(2) It is advisable to use reduction sleeves for lower values of cable diameter within cable range.

Hazardous Zone Fixed In-Line Receptacle

with Ex cable gland



927-072-022 FIXED IN-LINE RECEPTACLE WITH ENVIRONMENTAL CABLE ADAPTER AND EX CABLE GLAND

How To Order							
Sample Part Number	927-072	-022	-36-66	P1	F9	Y	/A
Series	927-072						
Style	-022 = Ex Cable Gland						
Shell Size - Insert Arrangement	See pages 22- 31						
Contact Type and Plating	P = Pin Contact, S = Socket Contact 1 = Silver Plated, 2 = Gold Plated						
Shell Material and Finish	F9 = Aluminium Alloy, Anodize Hardcoat						
Alternate Key Position	X, Y, Z, W (See Table on page 32) Omit for normal position						
Cable Range	A, B, C (See Table next page)						

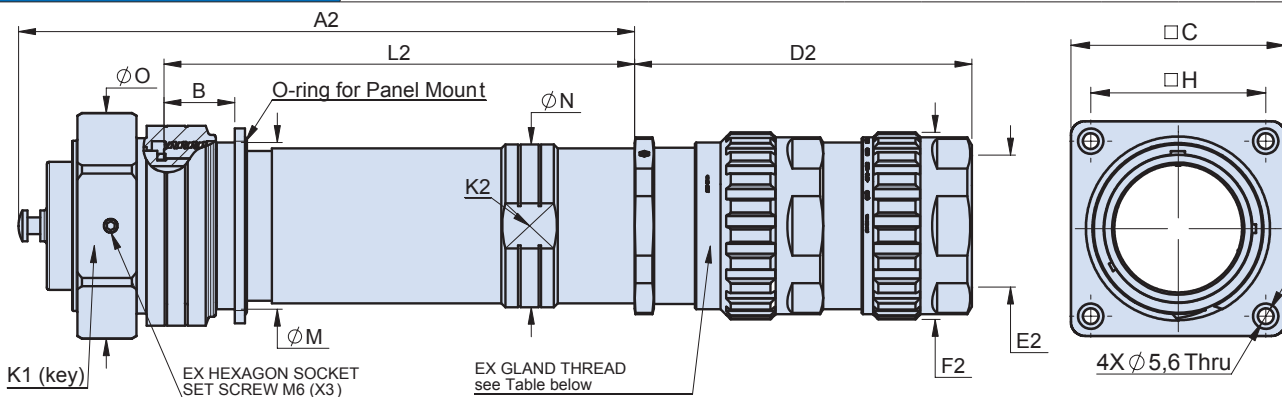

Shell Size	Dimensions														
	A2	B	C	D2	E2		Backshell Thread for Ex Gland	F2	H ± 0.1	K1	K2	L2	M	N	O
					Min.	Max.									
10SL	138	24.7	45	*	6.0	20.50	M20x1.5 M16x1.5	*	33	41	24	89	26	25	46
14S	160	24.7	45	*	6.0	20.50	M20x1.5 M16x1.5	*	33	45	26	109	30	28	49
16	190	27.6	51	*	6.0	20.50	M20x1.5 M16x1.5	*	39	49	32	134	34	34	54
18	191	27.6	57	*	6.0	26.0	M25x1.5 M20x1.5 M16x1.5	*	42	52	36	134	38	38.2	59
28	220	27.6	67	*	16.9	41.0	M40x1.5 M32x1.5 M25x1.5 M20x1.5 M16x1.5	*	52	65	48	164	52	54	72
36	241	27.6	76	*	22.0	52.60	M50x1.5 M40x1.5 M32x1.5 M25x1.5 M20x1.5 M16x1.5	*	62	78	61	184	65	63.5	88

(*) Dimension varies according to Ex Cable Gland.

Hazardous Zone Fixed In-Line Receptacle

with Ex cable gland



Cable Range Dimensions for Ex Cable Gland						
Shell Size	Cable Range Designator	Cable Type	Ex Gland Thread	Cable outer sheath range [mm]	Cable inner sheath range [mm]	Armor Range with Clamping Ring
36	A	Unarmored cable	M50x1.5	28 to 41		
	B		M40x1.5	22 to 33		
	C		M32x1.5	16,90 to 26		
	D		M25x1.5	12,50 to 20,50		
	E		M20x1.5	9 to 16		
	F		M20x1.5	6 to 12		
	G		M16x1.5	6 to 12		
	A1	Armored Cable	M50x1.5	36 to 52,60	28,90 to 44,40	0 to 1,0 and 1,5 to 2,5
	B1		M40x1.5	28 to 41	22 to 33	0 to 0,7 and 1,3 to 2,0
	C1		M32x1.5	22 to 33		0 to 0,7 and 1,3 to 2,0
	D1		M25x1.5	16,90 to 26		0 to 0,7 and 0,9 to 1,6
	E1		M25x1.5	12,50 to 20,50		0 to 0,7 and 0,7 to 1,4
	F1		M20x1.5	12,50 to 20,50		0 to 0,7 and 0,7 to 1,4
	G1		M20x1.5	9 to 16		0 to 0,7 and 0,7 to 1,25
H1	M20x1.5	6 to 12		0 to 0,7 and 0,7 to 1,25		
I1	M16x1.5	6 to 12		0 to 0,7 and 0,7 to 1,25		
28	A	Unarmored cable	M40x1.5	22 to 33		
	B		M32x1.5	16,90 to 26		
	C		M25x1.5	12,50 to 20,50		
	D		M20x1.5	9 to 16		
	E		M20x1.5	6 to 12		
	F		M16x1.5	6 to 12		
	A1	Armored Cable	M40x1.5	28 to 41	22 to 33	0 to 0,7 and 1,3 to 2,0
	B1		M32x1.5	22 to 33	16,90 to 26	0 to 0,7 and 1,3 to 2,0
	C1		M25x1.5	16,90 to 26	12,50 to 20,50	0 to 0,7 and 0,9 to 1,6
	D1		M25x1.5	12,50 to 20,50	9 to 14	0 to 0,7 and 0,7 to 1,4
	E1		M20x1.5	12,50 to 20,50	9 to 14	0 to 0,7 and 0,7 to 1,4
	F1		M20x1.5	9 to 16	6 to 12	0 to 0,7 and 0,7 to 1,25
	G1		M20x1.5	6 to 12	3 to 8,1	0 to 0,7 and 0,7 to 1,25
	H1		M16x1.5	6 to 12	3 to 8,1	0 to 0,7 and 0,7 to 1,25
18	A	Unarmored cable	M25x1.5	12,50 to 20,50		
	B		M20x1.5	9 to 16		
	C		M20x1.5	6 to 12		
	D		M16x1.5	6 to 12		
	A1	Armored Cable	M25x1.5	16,90 to 26	12,50 to 20,50	0 to 0,7 and 0,9 to 1,6
	B1		M25x1.5	12,50 to 20,50	9 to 14	0 to 0,7 and 0,7 to 1,4
	C1		M20x1.5	12,50 to 20,50	9 to 14	0 to 0,7 and 0,7 to 1,4
	D1		M20x1.5	9 to 16	6 to 12	0 to 0,7 and 0,7 to 1,25
	E1		M20x1.5	6 to 12	3 to 8,1	0 to 0,7 and 0,7 to 1,25
	F1		M16x1.5	6 to 12	3 to 8,1	0 to 0,7 and 0,7 to 1,25
16	A	Unarmored cable	M20x1.5	9 to 16		
	B		M20x1.5	6 to 12		
	C		M16x1.5	6 to 12		
	14S 10SL	A1	Armored Cable	M20x1.5	12,50 to 20,50	9 to 14
B1		M20x1.5		9 to 16	6 to 12	0 to 0,7 and 0,7 to 1,25
C1		M20x1.5		6 to 12	3 to 8,1	0 to 0,7 and 0,7 to 1,25
D1		M16x1.5		6 to 12	3 to 8,1	0 to 0,7 and 0,7 to 1,25

Hazardous Zone Fixed In-Line Receptacle

for Ex cable gland



927-072-022 FIXED IN-LINE RECEPTACLE WITH ENVIRONMENTAL CABLE ADAPTER FOR EX CABLE GLAND

How To Order							
Sample Part Number	927-072	-022	-36-66	P1	F9	Y	/A0
Series	927-072						
Style	-022 = Ex Cable Gland						
Shell Size - Insert Arrangement	See pages 22- 31						
Contact Type and Plating	P = Pin Contact, S = Socket Contact 1 = Silver Plated, 2 = Gold Plated						
Shell Material and Finish	F9 = Aluminium Alloy, Anodize Hardcoat						
Alternate Key Position	X, Y, Z, W (See Table on page 32) Omit for normal position						
Cable Range	A0, B0, C0 (See Table next page) Ex Cable Gland not supplied						

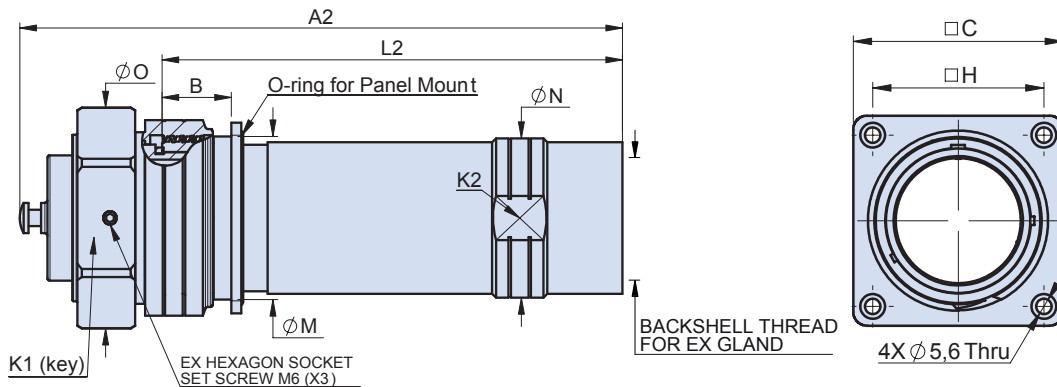

Dimensions											
Shell Size	A2	B	C	Backshell Thread for Ex Gland	H ± 0.1	K1	K2	L2	M	N	O
10SL	138	24.7	45	M20x1.5 M16x1.5	33	41	24	89	26	25	46
14S	160	24.7	45	M20x1.5 M16x1.5	33	45	26	109	30	28	49
16	190	27.6	51	M20x1.5 M16x1.5	39	49	32	134	34	34	54
18	191	27.6	57	M25x1.5 M20x1.5 M16x1.5	42	52	36	134	38	38.2	59
28	220	27.6	67	M40x1.5 M32x1.5 M25x1.5 M20x1.5 M16x1.5	52	65	48	164	52	54	72
36	241	27.6	76	M50x1.5 M40x1.5 M32x1.5 M25x1.5 M20x1.5 M16x1.5	62	78	61	184	65	63.5	88

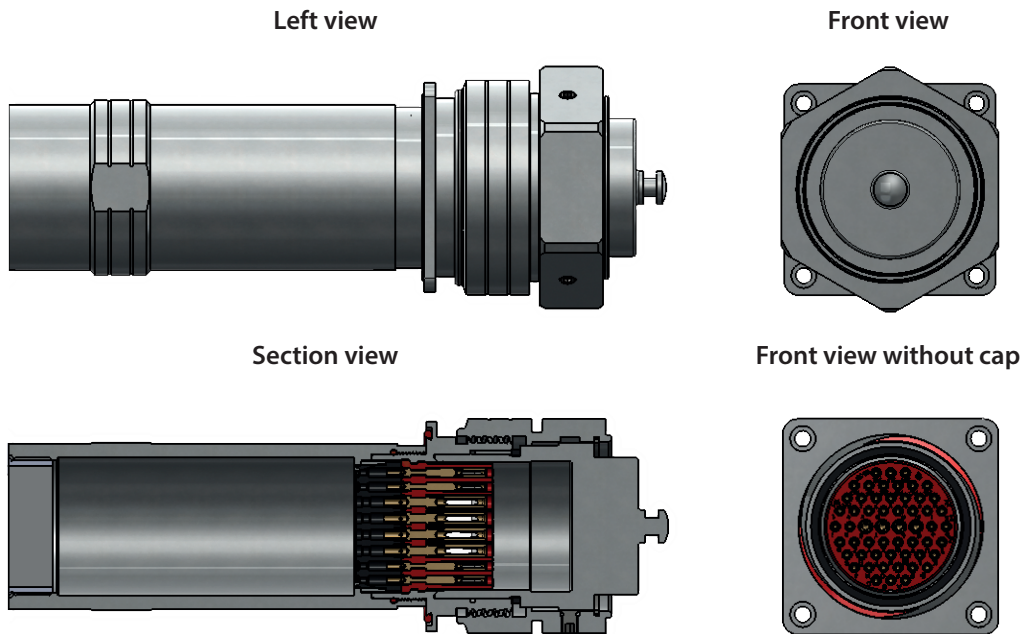

Cable Range Dimensions for Ex Cable Gland			
Shell Size	Cable Type	Cable Range Designator	Backshell Thread for Ex Gland
36	Armored/ Unarmored cable	A0	M50x1.5
		B0	M40x1.5
		C0	M32x1.5
		D0	M25x1.5
		E0	M20x1.5
		F0	M16x1.5
28	Armored/ Unarmored cable	A0	M40x1.5
		B0	M32x1.5
		C0	M25x1.5
		D0	M20x1.5
		E0	M16x1.5
18	Armored/ Unarmored cable	A0	M25x1.5
		B0	M20x1.5
		C0	M16x1.5
16 14S 10SL	Armored/ Unarmored cable	A0	M20x1.5
		B0	M16x1.5

Hazardous Zone Fixed In-Line Receptacle

with basket weave cable grip



927-072-032 FIXED IN-LINE RECEPTACLE WITH ENVIRONMENTAL CABLE ADAPTER AND BASKET WEAVE CABLE GRIP

How To Order							
Sample Part Number	927-072	-032	-36-66	P1	F9	Y	/A
Series	927-072						
Style	-032 = Basket Weave Cable Grip						
Shell Size - Insert Arrangement	See pages 22- 31						
Contact Type and Plating	P = Pin Contact, S = Socket Contact 1 = Silver Plated, 2 = Gold Plated						
Shell Material and Finish	F9 = Aluminium Alloy, Anodize Hardcoat						
Alternate Key Position	X, Y, Z, W (See Table on page 32) Omit for normal position						
Cable Range	A, B, C (See Table next page)						

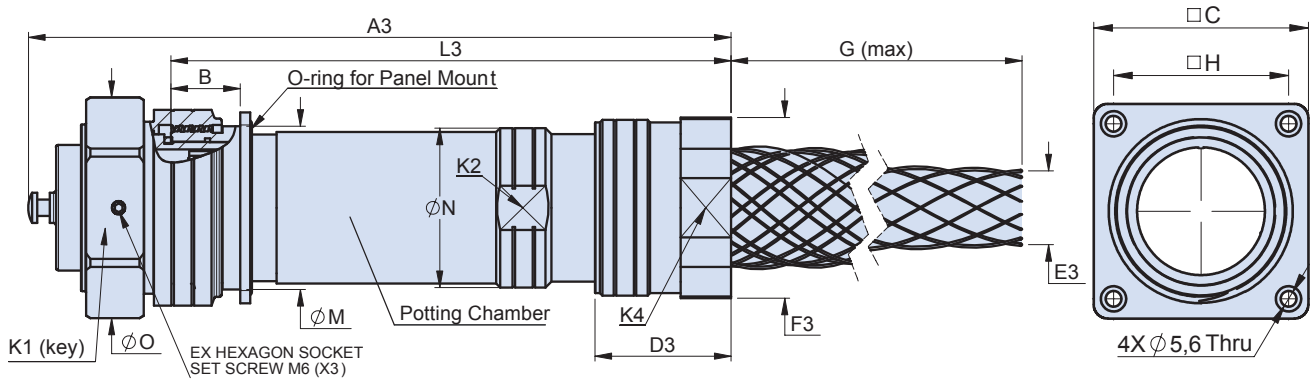

Dimensions																
Shell Size	A3	B	C	D3	E3		F3	G Max.	H ± 0.1	K1	K2	K4	L3	M	N	O
					Min.	Max.										
10SL	*	*	*	*	*	*	*	*	*	*	*	*	*	*	*	*
14S	*	*	*	*	*	*	*	*	*	*	*	*	*	*	*	*
16	217	27.6	51	35.5	8.0	19.0	42.0	179**	39	49	32	38	160	34	34.0	54
18	223	27.6	57	42.7	10.40	23.80	46.0	201**	42	52	36	42	166	38	38.2	59
28	264	27.6	67	54.2	17.5	34.1	64.0	239**	52	65	48	60	207	52	54.0	72
36	280	27.6	76	52.4	25.60	41.25	72.0	315**	62	78	61	68	224	65	63.5	88

(*) Please contact the factory.

(**) Max overall dimension; dimension less than max one, depending on Basket Weave Cable Range.

Hazardous Zone Fixed In-Line Receptacle with basket weave cable grip

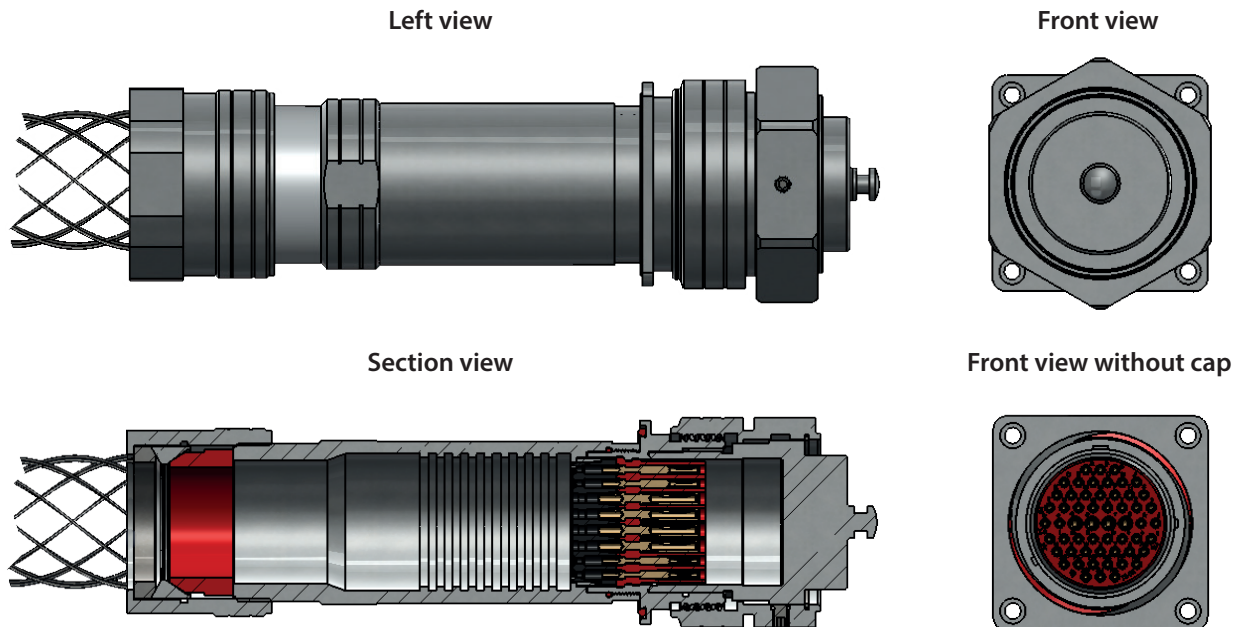

Cable Range Dimensions for Basketweave Cable Grip			
Shell Size	Cable Type (1)	Cable Range Designator	Cable Jacket Range [mm] (2)
36	Unarmored cable	A	39,40 to 41,25
		B	38,90 to 40,50
		C	34,50 to 38,50
		D	31,00 to 34,90
		E	29,40 to 33,30
		F	25,60 to 29,50 (1)
28	Unarmored cable	A	30,10 to 34,10
		B	28,50 to 32,00
		C	25,50 to 29,10
		D	23,40 to 26,60 (1)
		E	21,10 to 23,80
		F	17,50 to 21,40 (1)
18	Unarmored cable	A	19,60 to 23,80
		B	18,00 to 22,20 (1)
		C	15,50 to 19,00
		D	12,70 to 15,90
		E	10,40 to 12,70 (1)
16	Unarmored cable	A	15,50 to 19,00
		B	12,70 to 15,90 (1)
		C	10,40 to 12,70 (1)
		D	8,00 to 9,50 (1)

(1) Armoured cables may be used but the armour cannot be engaged.

(2) It is advisable to use reduction sleeves for lower values of cable diameter within cable range.

Hazardous Zone In-Line Receptacle with mechanical cable clamp



927-072-011 IN-LINE RECEPTACLE WITH ENVIRONMENTAL CABLE ADAPTER AND MECHANICAL CABLE CLAMP

How To Order							
Sample Part Number	927-072	-011	-36-66	P1	F9	Y	/A
Series	927-072						
Style	-011 = Mechanical Cable Clamp						
Shell Size - Insert Arrangement	See pages 22- 31						
Contact Type and Plating	P = Pin Contact, S = Socket Contact 1 = Silver Plated, 2 = Gold Plated						
Shell Material and Finish	F9 = Aluminium Alloy, Anodize Hardcoat						
Alternate Key Position	X, Y, Z, W (See Table on page 32) Omit for normal position						
Cable Range	A, B, C (See Table next page)						

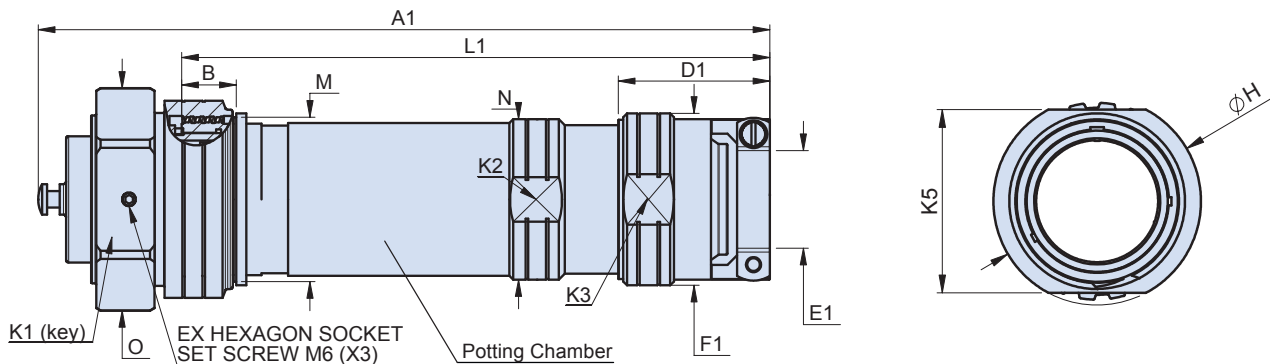

Shell Size	Dimensions														
	A1	B	D1	E1		F1	H	K1	K2	K3	K5	L1	M	N	O
				Min.	Max.										
10SL	179	22.8	40.7	4.50	11.12	28.0	37.0	41	22	27	34	129.5	26	25	46
14S	*	*	*	*	*	*	*	*	*	*	*	*	*	*	*
16	224	20.9	42.8	8.0	19.0	40.0	40.0	49	32	38	37	167.3	34	34	54
18	225	24.9	45.2	9.60	23.80	43.0	49.5	52	36	41	40	168	38	38.2	59
28	270	21.6	56.7	15.50	35.0	62.0	64.0	65	48	60	55	210	52	54	72
36	290	21.6	60	23.40	41.25	68.0	77.0	78	61	65	68	233	65	63.5	88

(*) Please contact the factory.

Hazardous Zone In-Line Receptacle with mechanical cable clamp

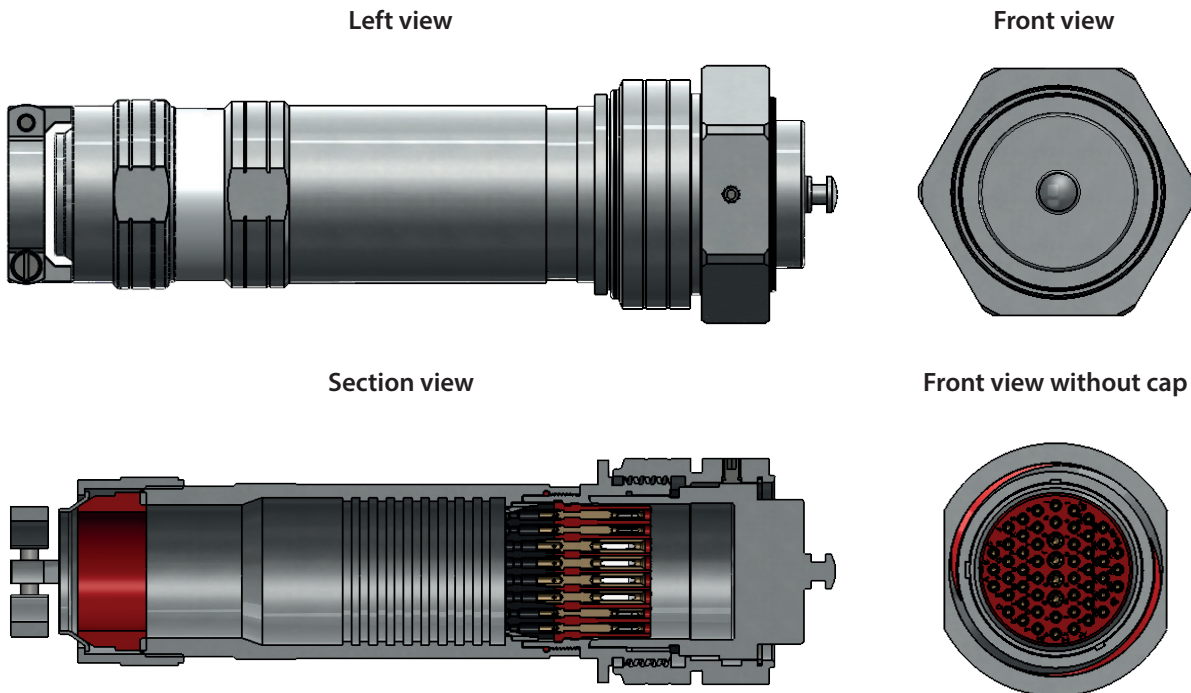

Cable Range Dimensions for Mechanical Cable Clamp			
Shell Size	Cable Type (1)	Cable Range Designator	Cable Jacket Range [mm] (2)
36	Unarmored cable	A	29,90 to 41,25
		B	23,40 to 35,00
28	Unarmored cable	A	28,50 to 35,00
		B	23,40 to 31,75
		C	15,50 to 23,80
18	Unarmored cable	A	15,50 to 23,80
		B	11,30 to 19,00
		C	9,60 to 15,90
16	Unarmored cable	A	11,30 to 19,00
		B	9,60 to 15,87
		C	8,00 to 13,48
10SL	Unarmored cable	A	5,84 to 11,12
		B	4,50 to 7,93

(1) Armored cables may be used but the armour cannot be engaged.

(2) It is advisable to use reduction sleeves for lower values of cable diameter within cable range.

SERIES 927-072

Hazardous Zone In-Line Receptacle

with Ex cable gland



927-072-021 IN-LINE RECEPTACLE WITH ENVIRONMENTAL CABLE ADAPTER AND EX CABLE GLAND

How To Order	
Sample Part Number	927-072 -021 -36-66 P1 F9 Y /A
Style	927-072 -021 = Ex Cable Gland
Shell Size - Insert Arrangement	See pages 22- 31
Contact Type and Plating	P = Pin Contact, S = Socket Contact 1 = Silver Plated, 2 = Gold Plated
Shell Material and Finish	F9 = Aluminium Alloy, Anodize Hardcoat
Alternate Key Position	X, Y, Z, W (See Table on page 32) Omit for normal position
Cable Range	A, B, C (See Table next page)

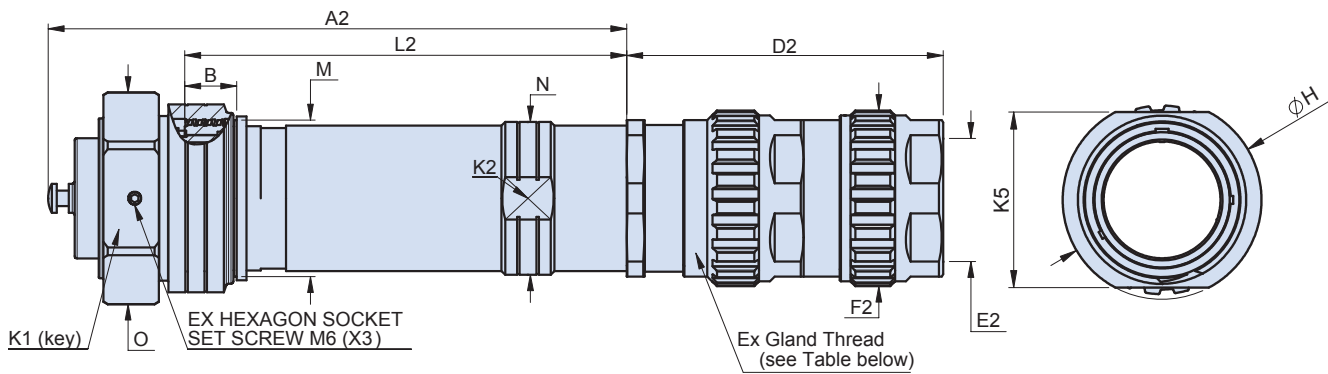

Dimensions															
Shell Size	A2	B	D2	E2		Backshell Thread for Ex Gland	F2	H	K1	K2	K5	L2	M	N	O
				Min.	Max.										
10SL	138	22.8	*	6.0	20.50	M20x1.5 M16x1.5	*	37	41	24	34	88.3	26	25	46
14S	159.8	20.7	*	6.0	20.50	M20x1.5 M16x1.5	*	35	45	26	32	109.3	30	28	49
16	190.3	20.9	*	6.0	20.50	M20x1.5 M16x1.5	*	40	49	32	37	133.6	34	34	54
18	190.5	20.9	*	6.0	26.0	M25x1.5 M20x1.5 M16x1.5	*	49.5	52	36	40	134	38	38,2	59
28	220.5	21.6	*	16.9	41.0	M40x1.5 M32x1.5 M25x1.5 M20x1.5 M16x1.5	*	64	65	48	55	164	52	54	72
36	241	21.6	*	22.0	52.60	M50x1.5 M40x1.5 M32x1.5 M25x1.5 M20x1.5 M16x1.5	*	77	78	61	68	184	65	63,5	88

(*) Dimension varies according to Ex Cable Gland.

Hazardous Zone In-Line Receptacle

with Ex cable gland



Cable Range Dimensions for Ex Cable Gland						
Shell Size	Cable Range Designator	Cable Type	Ex Gland Thread	Cable outer sheath range [mm]	Cable inner sheath range [mm]	Armor Range with Clamping Ring
36	A	Unarmored cable	M50x1.5	28 to 41		
	B		M40x1.5	22 to 33		
	C		M32x1.5	16,90 to 26		
	D		M25x1.5	12,50 to 20,50		
	E		M20x1.5	9 to 16		
	F		M20x1.5	6 to 12		
	G		M16x1.5	6 to 12		
	A1	Armored Cable	M50x1.5	36 to 52,60	28,90 to 44,40	0 to 1,0 and 1,5 to 2,5
	B1		M40x1.5	28 to 41	22 to 33	0 to 0,7 and 1,3 to 2,0
	C1		M32x1.5	22 to 33		0 to 0,7 and 1,3 to 2,0
	D1		M25x1.5	16,90 to 26		0 to 0,7 and 0,9 to 1,6
	E1		M25x1.5	12,50 to 20,50		0 to 0,7 and 0,7 to 1,4
	F1		M20x1.5	12,50 to 20,50		0 to 0,7 and 0,7 to 1,4
	G1		M20x1.5	9 to 16		0 to 0,7 and 0,7 to 1,25
H1	M20x1.5	6 to 12		0 to 0,7 and 0,7 to 1,25		
I1	M16x1.5	6 to 12		0 to 0,7 and 0,7 to 1,25		
28	A	Unarmored cable	M40x1.5	22 to 33		
	B		M32x1.5	16,90 to 26		
	C		M25x1.5	12,50 to 20,50		
	D		M20x1.5	9 to 16		
	E		M20x1.5	6 to 12		
	F		M16x1.5	6 to 12		
	A1	Armored Cable	M40x1.5	28 to 41	22 to 33	0 to 0,7 and 1,3 to 2,0
	B1		M32x1.5	22 to 33	16,90 to 26	0 to 0,7 and 1,3 to 2,0
	C1		M25x1.5	16,90 to 26	12,50 to 20,50	0 to 0,7 and 0,9 to 1,6
	D1		M25x1.5	12,50 to 20,50	9 to 14	0 to 0,7 and 0,7 to 1,4
	E1		M20x1.5	12,50 to 20,50	9 to 14	0 to 0,7 and 0,7 to 1,4
	F1		M20x1.5	9 to 16	6 to 12	0 to 0,7 and 0,7 to 1,25
	G1		M20x1.5	6 to 12	3 to 8,1	0 to 0,7 and 0,7 to 1,25
	H1		M16x1.5	6 to 12	3 to 8,1	0 to 0,7 and 0,7 to 1,25
18	A	Unarmored cable	M25x1.5	12,50 to 20,50		
	B		M20x1.5	9 to 16		
	C		M20x1.5	6 to 12		
	D		M16x1.5	6 to 12		
	A1	Armored Cable	M25x1.5	16,90 to 26	12,50 to 20,50	0 to 0,7 and 0,9 to 1,6
	B1		M25x1.5	12,50 to 20,50	9 to 14	0 to 0,7 and 0,7 to 1,4
	C1		M20x1.5	12,50 to 20,50	9 to 14	0 to 0,7 and 0,7 to 1,4
	D1		M20x1.5	9 to 16	6 to 12	0 to 0,7 and 0,7 to 1,25
	E1		M20x1.5	6 to 12	3 to 8,1	0 to 0,7 and 0,7 to 1,25
	F1		M16x1.5	6 to 12	3 to 8,1	0 to 0,7 and 0,7 to 1,25
16 14S 10SL	A	Unarmored cable	M20x1.5	9 to 16		
	B		M20x1.5	6 to 12		
	C		M16x1.5	6 to 12		
	A1	Armored Cable	M20x1.5	12,50 to 20,50	9 to 14	0 to 0,7 and 0,7 to 1,4
	B1		M20x1.5	9 to 16	6 to 12	0 to 0,7 and 0,7 to 1,25
	C1		M20x1.5	6 to 12	3 to 8,1	0 to 0,7 and 0,7 to 1,25
	D1		M16x1.5	6 to 12	3 to 8,1	0 to 0,7 and 0,7 to 1,25

Hazardous Zone In-Line Receptacle

for Ex cable gland



927-072-021 IN-LINE RECEPTACLE WITH ENVIRONMENTAL CABLE ADAPTER FOR EX CABLE GLAND

How To Order							
Sample Part Number	927-072	-021	-36-66	P1	F9	Y	/A0
	927-072						
Style	-021 = Ex Cable Gland						
Shell Size - Insert Arrangement	See pages 22- 31						
Contact Type and Plating	P = Pin Contact, S = Socket Contact 1 = Silver Plated, 2 = Gold Plated						
Shell Material and Finish	F9 = Aluminium Alloy, Anodize Hardcoat						
Alternate Key Position	X, Y, Z, W (See Table on page 32) Omit for normal position						
Cable Range	A0, B0, C0 (See Table next page) Ex Cable Gland not supplied						

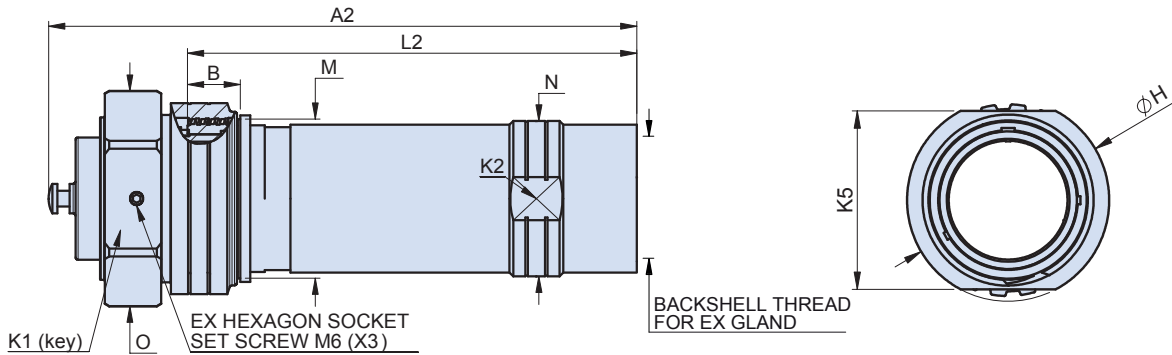

Dimensions											
Shell Size	A2	B	Backshell Thread for Ex Gland	H	K1	K2	K5	L2	M	N	O
10SL	138	22.8	M20x1.5 M16x1.5	37	41	24	34	88.3	26	25	46
14S	159.8	20.7	M20x1.5 M16x1.5	35	45	26	32	109.3	30	28	49
16	190.3	20.9	M20x1.5 M16x1.5	40	49	32	37	133.6	34	34	54
18	190.5	20.9	M25x1.5 M20x1.5 M16x1.5	49.5	52	36	40	134	38	38,2	59
28	220.5	21.6	M40x1.5 M32x1.5 M25x1.5 M20x1.5 M16x1.5	64	65	48	55	164	52	54	72
36	241	21.6	M50x1.5 M40x1.5 M32x1.5 M25x1.5 M20x1.5 M16x1.5	77	78	61	68	184	65	63,5	88

Hazardous Zone In-Line Receptacle

for Ex cable gland



Left view

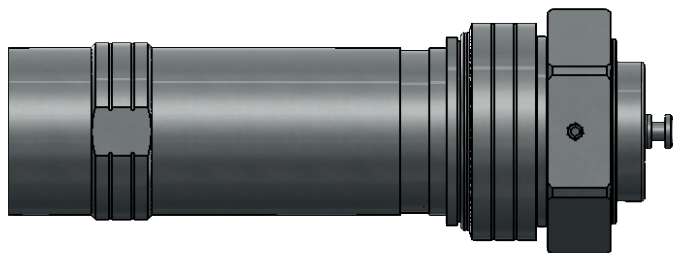

Front view



Section view

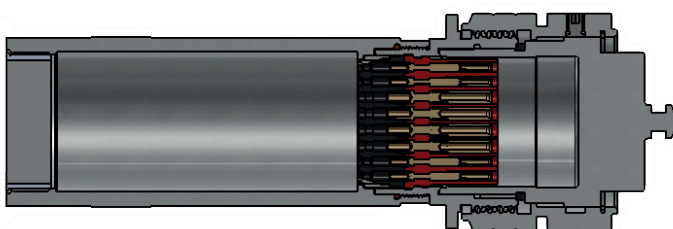

Front view without cap

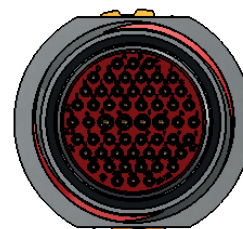

Cable Range Dimensions for Ex Cable Gland			
Shell Size	Cable Type	Cable Range Designator	Backshell Thread for Ex Gland
36	Armored/ Unarmored cable	A0	M50x1.5
		B0	M40x1.5
		C0	M32x1.5
		D0	M25x1.5
		E0	M20x1.5
		F0	M16x1.5
28	Armored/ Unarmored cable	A0	M40x1.5
		B0	M32x1.5
		C0	M25x1.5
		D0	M20x1.5
		E0	M16x1.5
18	Armored/ Unarmored cable	A0	M25x1.5
		B0	M20x1.5
		C0	M16x1.5
16 14S 10SL	Armored/ Unarmored cable	A0	M20x1.5
		B0	M16x1.5

Hazardous Zone In-Line Receptacle

with basket weave cable grip



927-072-031 IN-LINE RECEPTACLE WITH ENVIRONMENTAL CABLE ADAPTER AND BASKET WEAVE CABLE GRIP

How To Order							
Sample Part Number	927-072	-031	-36-66	P1	F9	Y	/A
Series	927-072						
Style	-031 = Basket Weave Cable Grip						
Shell Size - Insert Arrangement	See pages 22- 31						
Contact Type and Plating	P = Pin Contact, S = Socket Contact 1 = Silver Plated, 2 = Gold Plated						
Shell Material and Finish	F9 = Aluminium Alloy, Anodize Hardcoat						
Alternate Key Position	X, Y, Z, W (See Table on page 32) Omit for normal position						
Cable Range	A, B, C (See Table next page)						

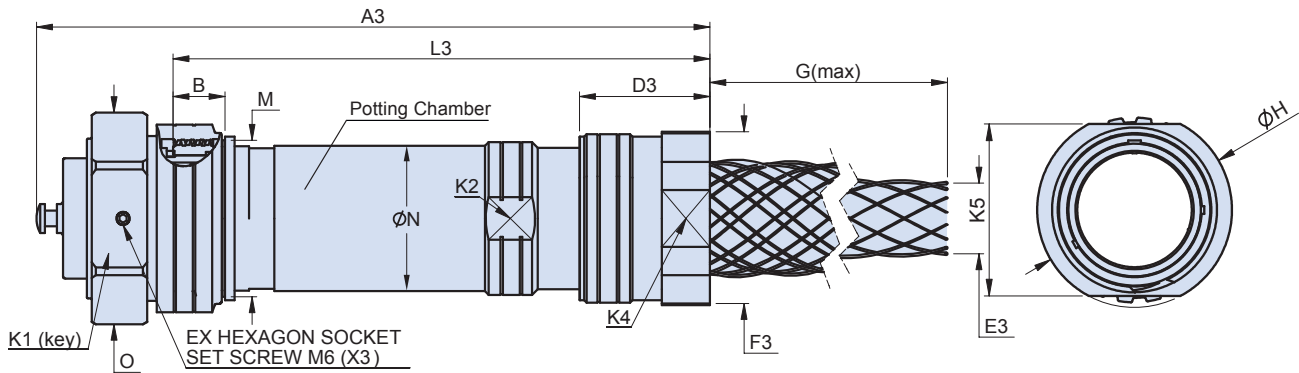

Shell Size	Dimensions															
	A3	B	D3	E3		F3	G Max.	H	K1	K2	K4	K5	L3	M	N	O
				Min.	Max.											
10SL	*	*	*	*	*	*	*	*	*	*	*	*	*	*	*	*
14S	*	*	*	*	*	*	*	*	*	*	*	*	*	*	*	*
16	217.1	20.9	35.5	8.0	19.0	42.0	170.4	40.0	49	32	38	37	160.4	34	34.0	54
18	223	20.9	42.7	10.40	23.80	46.0	201**	49.5	52	36	42	40	163.5	38	38.2	59
28	264	21.6	54.2	17.5	34.1	64.0	239	64.0	65	48	60	55	207.3	52	54.0	72
36	280	21.6	52.4	25.60	41.25	72.0	315**	77.0	78	61	68	68	223.2	65	63.5	88

(*) Please contact the factory.

(**) Max overall dimension; dimension less than max one, depending on Basket Weave Cable Range.

Hazardous Zone In-Line Receptacle

with basket weave cable grip

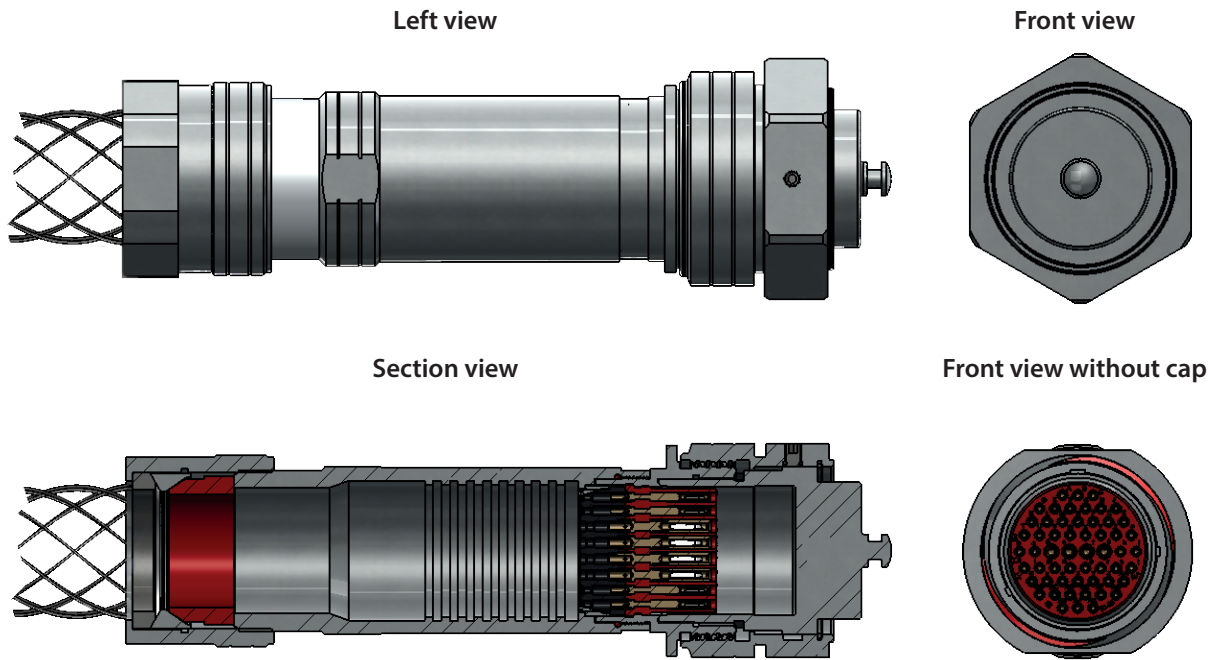

Cable Range Dimensions for Basketweave Cable Grip			
Shell Size	Cable Type (1)	Cable Range Designator	Cable Jacket Range [mm] (2)
36	Unarmored cable	A	39,40 to 41,25
		B	38,90 to 40,50
		C	34,50 to 38,50
		D	31,00 to 34,90
		E	29,40 to 33,30
		F	25,60 to 29,50 (1)
28	Unarmored cable	A	30,10 to 34,10
		B	28,50 to 32,00
		C	25,50 to 29,10
		D	23,40 to 26,60 (1)
		E	21,10 to 23,80
		F	17,50 to 21,40 (1)
18	Unarmored cable	A	19,60 to 23,80
		B	18,00 to 22,20 (1)
		C	15,50 to 19,00
		D	12,70 to 15,90
		E	10,40 to 12,70 (1)
		F	8,00 to 9,50 (1)
16	Unarmored cable	A	15,50 to 19,00
		B	12,70 to 15,90 (1)
		C	10,40 to 12,70 (1)
		D	8,00 to 9,50 (1)

(1) Armoured cables may be used but the armour cannot be engaged.

(2) It is advisable to use reduction sleeves for lower values of cable diameter within cable range.

Hazardous Zone Panel-Mount Fixed Receptacle with potting well and auxiliary lock nut



927-072-003 PANEL-MOUNT FIXED RECEPTACLE WITH POTTING WELL AND AUXILIARY LOCK NUT*

How To Order						
Sample Part Number	927-072	-003	-36-66	P1	F9	Y
Series	927-072					
Style	-003 = Panel Mount Fixed Receptacle Component ⁽¹⁾ -004 = Panel Mount Fixed Receptacle Equipment ⁽²⁾					
Shell Size - Insert Arrangement	See pages 22- 31					
Contact Type and Plating	P = Pin Contact, S = Socket Contact 1 = Silver Plated, 2 = Gold Plated					
Shell Material and Finish	F9 = Aluminium Alloy, Anodize Hardcoat					
Alternate Key Position	X, Y, Z, W (See Table on page 32) Omit for normal position					

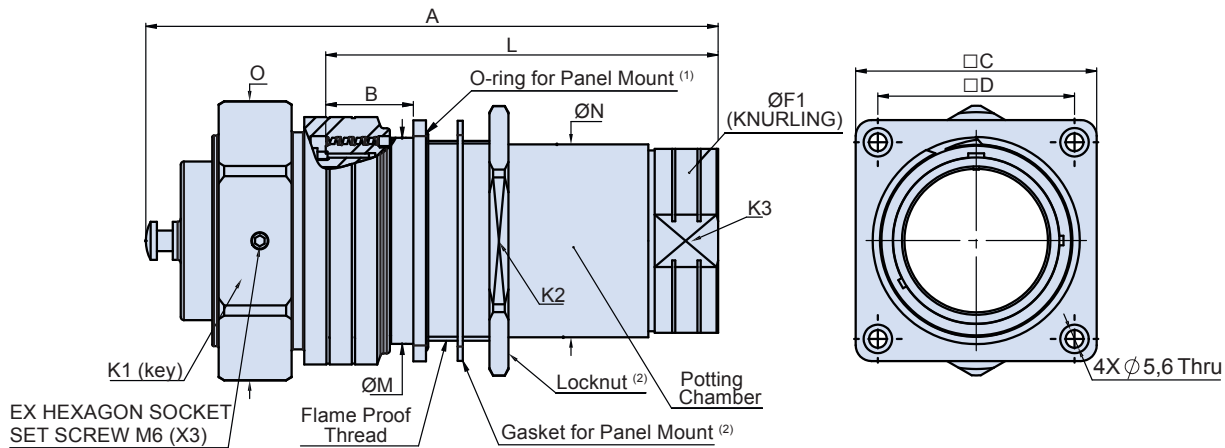

- (1) For Mounting on Ex d enclosure: use only O-ring for Panel Mount.
For Screw type use only O-ring for Panel Mount.
- (2) For Mounting on Ex e enclosure: use only Gasket for Panel Mount and Locknut.
For Jam Nut type: use only Gasket for Panel Mount and Locknut

Dimensions														
Shell Size	A	B	C	D ± 0.1	F1	K1	K2	K3	L	M	N	O	Flame Proof Thread	Min Full Thread Length
10SL	130.4	24.7	45	33	22	41	46	21	80.9	26	21	46	M25 x 1.5 6 g	19
14S	131.4	24.7	45	33	22.5	45	46	21	80.9	30	22.8	49	M25x 1.5 6 g	19
16	171.3	27.6	51	39	29.5	49	50	28	114.6	34	30	54	M32 x 1.5 6 g	19
18	*	*	*	*	*	*	*	*	*	*	*	*	*	*
28	178.3	27.6	67	52	47.5	65	65	46	121.6	52	48	72	M50 x 1.5 6 g	19
36	180.4	27.6	76	62	60.3	78	75	58	123.7	65	60.8	88	M63 x 1.5 6 g	19

(*) Final IEC ATEX Ex d certification pending for size 18. Consult the factory for status.

with potting well and auxiliary lock nut

Left view

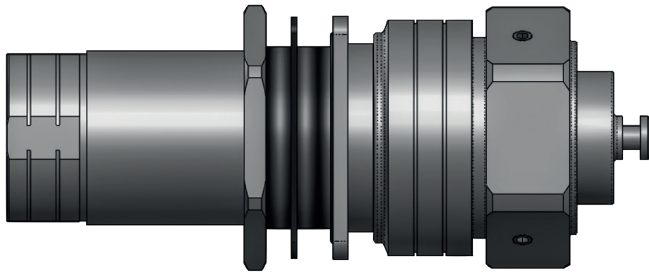

Front view

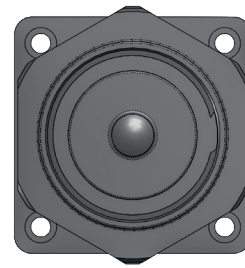

Section view

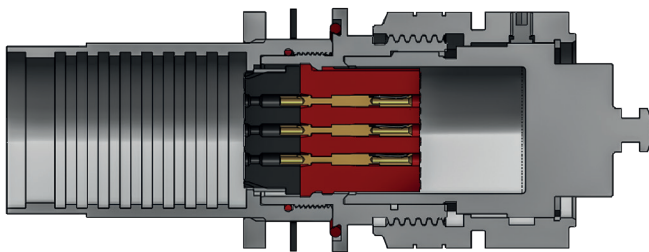

Front view without cap

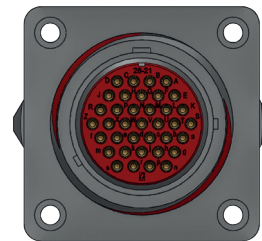

Cable Range Dimensions for Panel Mount		
Shell Size	Cable Type (1)	Cable Jacket Range [mm]
36	Unarmoured cable	23,4 to 41,25
28	Unarmoured cable	15,50 to 35,00
16	Unarmoured cable	8,00 to 19,00
14S	Unarmoured cable	5,84 to 11,12
10SL	Unarmoured cable	4,5 to 11,12

(1) Armoured cables may be used but the armour cannot be engaged.

Cable reduction sleeve

REDUCTION SLEEVES FOR CABLE

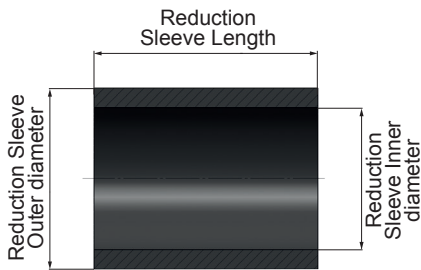

Reduction Sleeve for use with Mechanical Cable Clamp or Basketweave Cable Grip

Shell Size	Sleeve P/N	Sleeve inner diameter [mm]	Sleeve outer diameter [mm]	Sleeve length [mm]	Use for cable range [mm]
36	D-3420-28A	31,80	40,60	50,20	29,90 to 32,00
	D-3420-24A	28,50	33,90	51,10	23,40 to 28,50
28	D-3420-20A	23,80	31,50	50,90	23,40 to 23,80
	D-3420-16A	19,00	23,60	50,90	17,50 to 19,00
18	D-3420-16A	19,00	23,60	50,90	15,50 to 19,00
	D-3420-12A	13,74	18,50	50,90	11,30 to 13,74
	D-3420-10A	11,10	15,70	50,50	9,60 to 11,10
16	D-3420-12A	13,74	18,50	50,90	12,70 to 13,80
	D-3420-10A	11,10	15,70	50,50	10,40 to 11,10
	D-3420-8A	11,10	13,50	50,50	8,00 to 9,50
10SL	D-3420-6A	7,93	10,50	50,50	5,84 to 7,93
	D-3420-4A	5,56	7,63	50,50	4,50 to 5,56

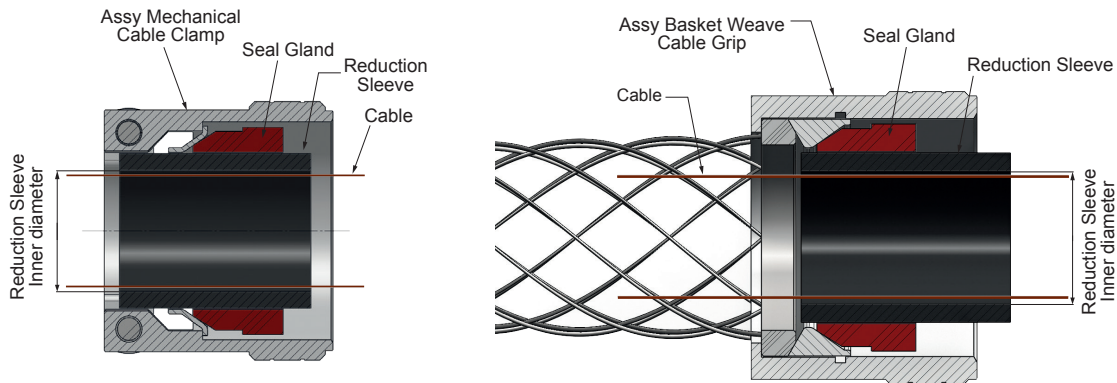

Ex CABLE GLAND ASSEMBLY, EXPLODED VIEW

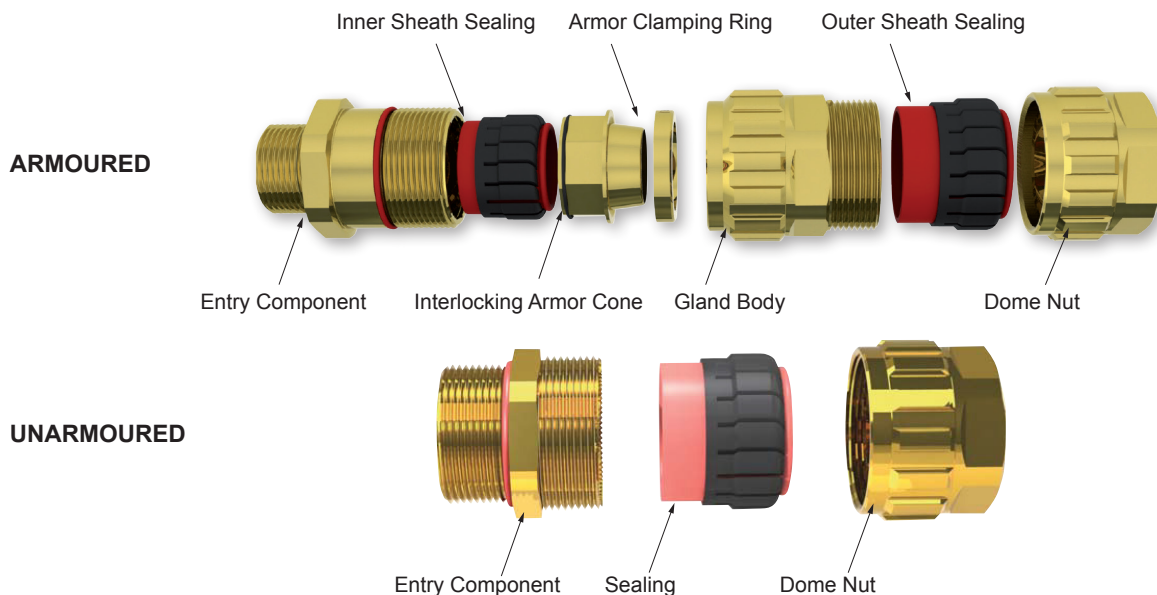

Pin Crimp Contacts

PIN CRIMP CONTACTS

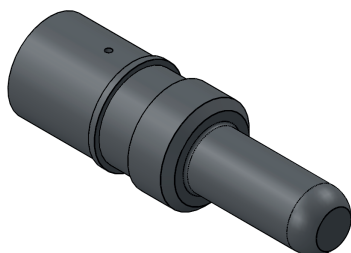
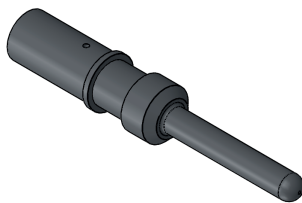
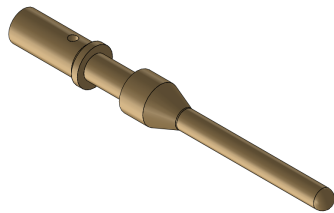

Series 927-072 contacts for size #16s through size #0 wire. Copper alloy with silver or gold plating, terminate to wire with standard crimp tools. Contacts are front-release. Use in series 927-072 connectors.

Pin contact with silver plating. For properties please consult table Materials on page 14 row Item Crimp Socket and Pin Contacts. Highly conductive silver plating is ideal for high current applications.

Pin contact with gold plating is used to improve protection from corrosive environments. For Electric properties, please consult table on page 7.

Pin Crimp Contacts Table				
Size [AWG]	Wire Size [AWG](1)	Wire Size [mm ²]	Silver Pin Contact PN	Gold Pin Contact PN
16S*	22	0.25	D-20-40553	D-21-40553
	20	0.5		
	18	0.75-1		
	16	1.5		
16	22	0.25	D-20-40557	D-21-40557
	20	0.5		
	18	0.75-1		
	16	1.5		
12	16	1.5	D-20-40561	D-21-40561
	14-12	2.5		
8	12	4	D-20-40792	-
	10	6		
	8	10		
4	8	10	D-20-113474-4P	-
	6	16		
	4	25		
0	1	50	D-20-113474-1P	-
	0	-		

* S = short (see length contacts)

(1) Other contact wire size on request, please consult the factory.

Pin Contact Current Ratings and Resistance			
Contact Size AWG	Max Rated Current [A]		Max Contact Resistance [mΩ]
	IAW N.E.C. (2)	IAW VG95234 (3)	
16-16S	3	3	6.0
	7.5	7.5	
	9	9	
	16	20	
12	16	20	3.0
	30	32	
8	30	32	1.0
	40	42	
	50	60	
4	50	60	0.5
	70	85	
	90	120	
0	132	190	0.3
	155	220	

(2) Non-circuit breaking contacts rated current as per N.E.C. (National Electrical Code) based on arcing control. Use a cable of minimum rated temperature of 90°C.

(3) Values extrapolated from rated current chart of VG95234-1, at ambient temperature of 40°C.

Pin Crimp Contacts

PIN CRIMP CONTACTS

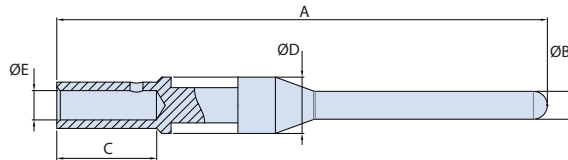

Contact Size	Finish	Part Number	A	ØB	C	ØD	ØE
16S	Silver	D-20-40553	31,25	1,57	7,45	3,1	1,7
	Gold	D-21-40553					
16	Silver	D-20-40557	36,65	1,57	7,75	3,1	1,7
	Gold	D-21-40557					
12	Silver	D-20-40561	41,85	2,38	8,5	4,8	2,5
	Gold	D-21-40561					

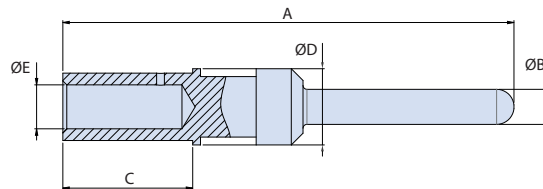

Contact Size	Finish	Part Number	A	ØB	C	ØD	ØE
8	Silver	D-20-40792	46,2	3,59	13,3	7,8	4,5

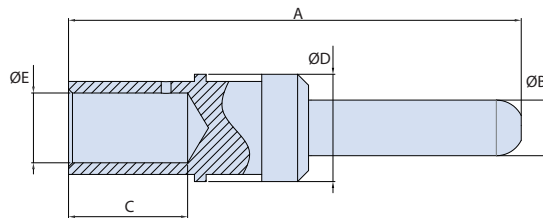

Contact Size	Finish	Part Number	A	ØB	C	ØD	ØE
4	Silver	D-20-113474-4P	46,4	5,7	12,9	11	7,15

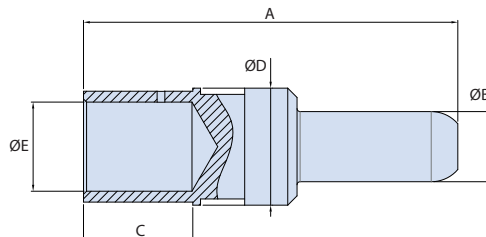

Contact Size	Finish	Part Number	A	ØB	C	ØD	ØE
0	Silver	D-20-113474-1P	48,3	9,05	14,1	15,1	11,5

SERIES 927-072 Contacts, Tools, and Accessories



Socket Crimp Contacts

SOCKET CRIMP CONTACTS

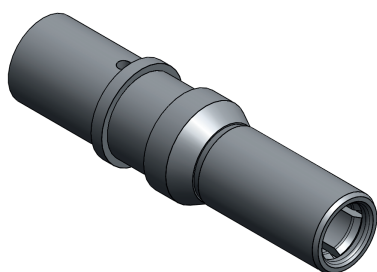
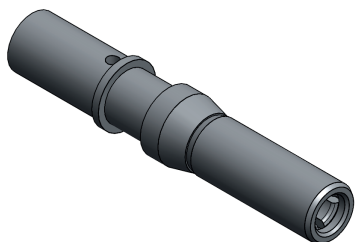
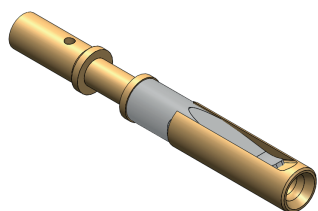

Series 927-072 contacts for size #16s through size #0 wire. Copper alloy with silver or gold plating, terminate to wire with standard crimp tools. Contacts are front-release. Use in series 927-072 connectors.

Socket contact with silver plating. For properties please consult table Materials on page 14 row Item Crimp Socket and Pin Contacts. Highly conductive silver plating is ideal for high current applications.

Socket contact with gold plating is used to improve protection from corrosive environments. For Electric properties, please consult table on page 7.

Socket Crimp Contacts Table					
Size [AWG]	Wire Size [AWG](1)	Wire Size [mm ²]	Silver Socket Contact PN	Gold Socket Contact PN	Contact type
16S*	22	0.25	D-30-40552	D-31-40552	Spring clip
	20	0.5			
	18	0.75-1			
	16	1.5			
16	22	0.25	D-30-40556	D-31-40556	Spring clip
	20	0.5			
	18	0.75-1			
	16	1.5			
12	16	1.5	D-30-40560	D-31-40560	Spring clip
	14-12	2.5			
8	12	4	D-30-40793	-	Hood
	10	6			
	8	10			
4	8	10	D-30-113474-4S-1	-	Hood
	6	16			
	4	25			
0	1	50	D-30-113474-1S-3	-	Hood
	0	-			

* S = short (see length contacts)

(1) Other contact wire size on request, please consult the factory.

Contact Size AWG	Socket Contact Current Ratings and Resistance		Max Contact Resistance [mΩ]
	Max Rated Current [A]		
	IAW N.E.C. (2)	IAW VG95234 (3)	
16-16S	3	3	6.0
	7.5	7.5	
	9	9	
	16	20	
12	16	20	3.0
	30	32	
8	30	32	1.0
	40	42	
	50	60	
4	50	60	0.5
	70	85	
	90	120	
0	132	190	0.3
	155	220	

(2) Non-circuit breaking contacts rated current as per N.E.C. (National Electrical Code) based on arcing control. Use a cable of minimum rated temperature of 90°C.

(3) Values extrapolated from rated current chart of VG95234-1, at ambient temperature of 40°C.

SERIES 927-072
Contacts, Tools, and Accessories
Socket Crimp Contacts



SOCKET CRIMP CONTACTS

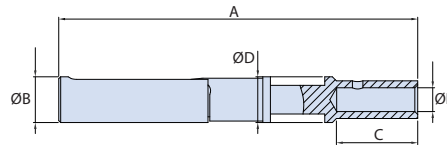

Contact Size	Finish	Part Number	A	ØB	C	ØD	ØE
16S	Silver	D-30-40552	26,7	3,2	7,5	3,2	1,7
	Gold	D-31-40552					
16	Silver	D-30-40556	36,5	3,2	7,8	3,2	1,7
	Gold	D-31-40556					
12	Silver	D-30-40560	37,65	4,8	8,5	4,8	2,5
	Gold	D-31-40560					

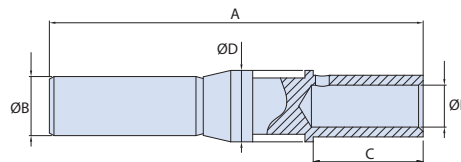

Contact Size	Finish	Part Number	A	ØB	C	ØD	ØE
8	Silver	D-30-40793	40,8	6,45	12	7,8	4,58

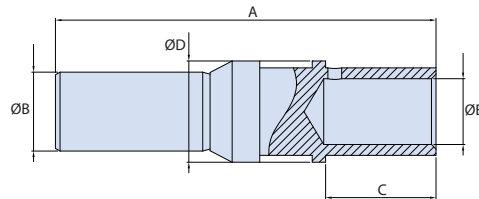

Contact Size	Finish	Part Number	A	ØB	C	ØD	ØE
4	Silver	D-30-113474-4S-1	41,35	8,57	12	11	7,15

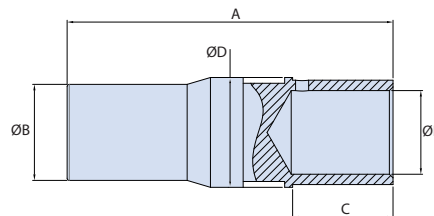

Contact Size	Finish	Part Number	A	ØB	C	ØD	ØE
0	Silver	D-30-113474-1S-3	44,8	13,2	13,8	15,1	11,5

Wire hole sealing plug (contact insert)

WIRE HOLE PLUG FOR CONTACT INSERTS

Part Number	Contact Size	ØA	ØB	C	L	Color
D-10-305045-16	16S - 16	2.6	2.2	3.2	15.7	Blue
D-10-101033-13	12	4.6	3.7	3.2	11.9	Yellow
D-10-305045-8	8	7.6	6.4	3.1	11.8	White
D-10-305045-4	4	10.9	9.7	3.1	11.8	Green
D-10-305045-0	0	15.0	13.5	4.3	14.3	Black

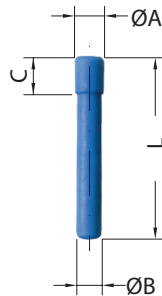

D-10-305045-16

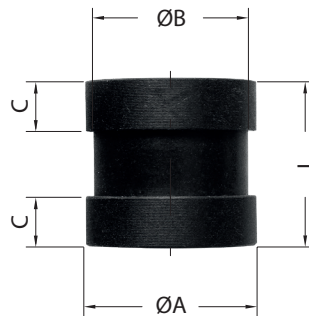

D-10-101033-13
D-10-305045-XX

NOTES

Contact Hole Plug - Insert Version.

Used to fill an insert cavity in order to maintain the environmental seal when a cavity is without contact.

Wire hole sealing plug (sealing grommet)

WIRE HOLE PLUG FOR WIRE SEALING GROMMETS

Part Number	Contact Size	ØA	ØB	C	L	Color
D-10-101033-12	16S - 16	3.7	2.8	3.2	11.9	Blu / Blue
D-10-101033-13	12	4.6	3.7	3.2	11.9	Giallo / Yellow
D-10-101033-14	8	5.8	5.0	3.2	11.9	Bianco / White
D-10-101033-15	4	8.5	7.6	3.2	11.9	Verde / Green
D-10-101033-16	0	13.5	12.8	3.2	11.9	Nero / Black

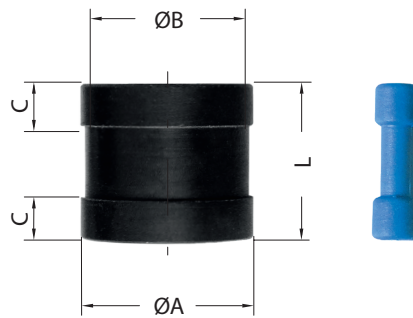

D-10-101033-XX

NOTES

Contact Hole Plug - Grommet Version.

Used to fill a grommet cavity in order to maintain the environmental seal when a cavity is without contact.

SERIES 927-072 Contacts, Tools, and Accessories

Crimp tools



MANUAL AND PNEUMATIC CRIMP TOOLS



Manual Crimp Tool

Contact Size	Wire Size	Manual Crimp Tool			Pneumatic Crimp Tool		
		Manual Tool	Turret	Universal Locator	Type A		
					Pneumatic Tool	Turret	Universal Locator
16s	16	M.105007	M.105009*	M.105012**	M.105002	M.105009*	M.105012**
16	16	M.105007	M.105009*	M.105012**	M.105002	M.105009*	M.105012**
12	12	M.105007	M.105009*	M.105012**	M.105002	M.105009*	M.105012**
8	8	/	/	/	/	/	/
4	4	/	/	/	/	/	/
0	0	/	/	/	/	/	/

* Socket contact only
** Pin contact only



Turret



Universal Locator



Pneumatic Crimp Tool Type A



Turret for Pneumatic Crimp Tool Type A

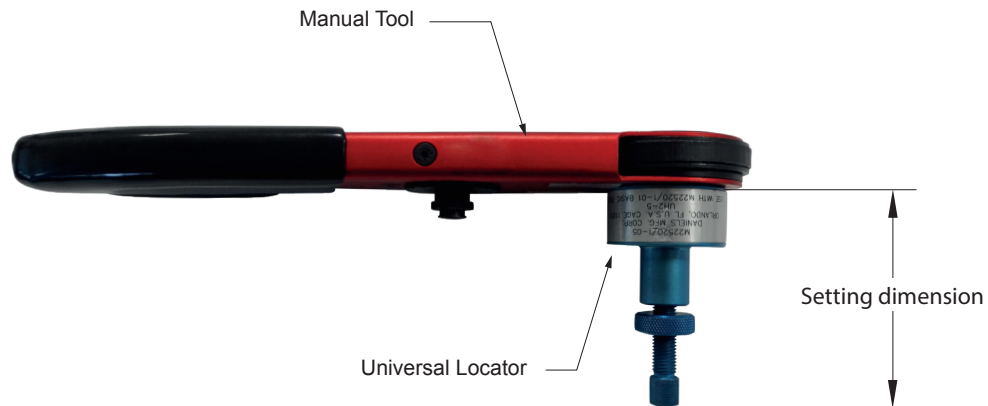

Contact Size	Wire Size	Manual Crimp Tool		
		Manual Tool	Universal Locator	Setting dimension [mm]
16s	16	M.105007	M.105012	67.7
16	16	M.105007	M.105012	73.0
12	12	M.105007	M.105012	85.4

Crimp tools for large contacts Contact insertion and removal tools

HYDRAULIC AND PNEUMATIC CRIMP TOOLS



Hydraulic Crimp Tool

Contact Size	Wire Size	Hydraulic Crimp Tool		Pneumatic Crimp Tool			
		Hydraulic Tool	Die	Type B			
				Pneumatic Tool	Die	Locator Pin	Locator Socket
16s	16	/	/	/	/	/	/
16	16	/	/	/	/	/	/
12	12	/	/	/	/	/	/
8	8	M.112004	M.112005	M.112000	M.112001	M.112308	M.112309
4	4	M.112004	M.112006	M.112000	M.112002	M.112307	M.112311
0	0	M.112004	M.112010	M.112000	M.112003	M.112306	M.112313

* Socket contact only ** Pin contact only



Die for Oleodinamic Crimp Tool



Pneumatic Crimp Tool Type B



Die For Pneumatic Crimp Tool Type B



Locator for Pneumatic Crimp Tool Type B

INSERTION AND REMOVAL TOOLS

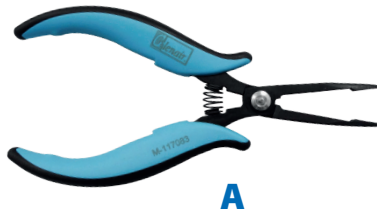

A

Contact Size	Insertion Tool	Figure	Removal Tool	Figure
16S	M.117083	A	M.118250	C
16	M.117083	A	M.118250	C
12	M.117082	A	M.118250	C
8	M.117344	B	M.118260	D
4	M.117347	B	M.118270	D
0	M.117348	B	M.118280	D



B



C



D

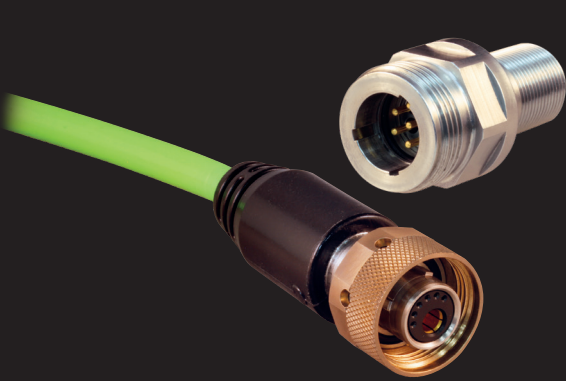

SeaKing 10K PSI high-density subsea connectors and cables



SNEAK PEEK: SuperG55 dry-mate 10K PSI underwater electrical connectors



Series 80 AquaMouse subsea and hermetic connectors



SNEAK PEEK: Marine Molded dry mate submersion-zone connectors

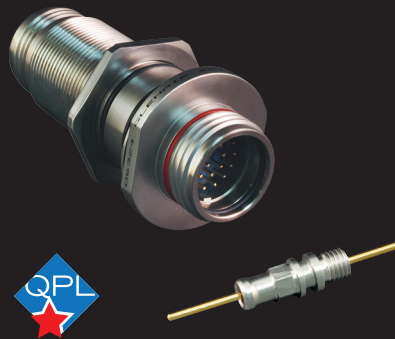

Glass-sealed high-pressure to 30K PSI hermetic bulkhead connector feed-thrus and HTHP

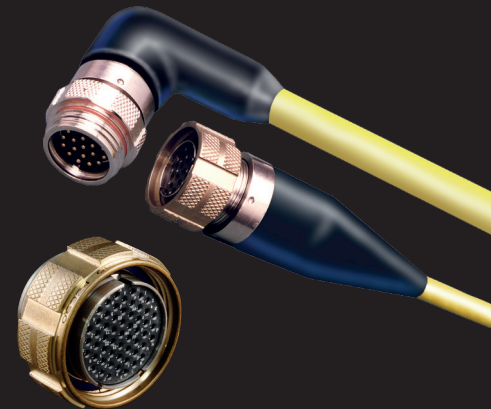

Series 22 GeoMarine® 5K PSI transition-zone and subsea connectors and cables



ITS-Ex ATEX-qualified and approved explosive zone connectors



MIL-DTL-28840 qualified Navy electrical connectors and backshell fittings

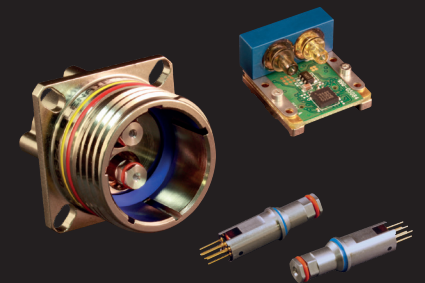

Harsh environment fiber optic connectors and opto-electronic transceivers and media converters



MISSION-CRITICAL INTERCONNECT SOLUTIONS

Glenair, Inc.

1211 Air Way • Glendale, California • 91201-2497

Telephone: 818-247-6000 • Fax: 818-500-9912 • sales@glenair.com

www.glenair.com

Glenair Power Products Group

20 Sterling Drive
Wallingford, CT
06492

Telephone:
203-741-1115
Facsimile:
203-741-0053
sales@glenair.com

Glenair UK Ltd

40 Lower Oakham Way
Oakham Business Park
Mansfield, Notts
NG18 5BY England

Telephone:
+44-1623-638100
Facsimile:
+44-1623-638111
sales@glenair.co.uk

Glenair Microway Systems

7000 North Lawndale Avenue
Lincolnwood, IL
60712

Telephone:
847-679-8833
Facsimile:
847-679-8849

Glenair Nordic AB

Gustav III : S Boulevard 46
SE-169 27 Solna
Sweden

Telephone:
+46-8-50550000
sales@glenair.se

Glenair Electric GmbH

Schaberweg 28
61348 Bad Homburg
Germany

Telephone:
06172 / 68 16 0
Facsimile:
06172 / 68 16 90
info@glenair.de

Glenair Iberica

C/ La Vega, 16
45612 Velada
Spain

Telephone:
+34-925-89-29-88
Facsimile:
+34-925-89-29-87
sales@glenair.es

Glenair Italia S.p.A.

Via Del Lavoro, 7
40057 Quarto Inferiore –
Granarolo dell'Emilia
Bologna, Italy

Telephone:
+39-051-782811
Facsimile:
+39-051-782259
info@glenair.it

Glenair France SARL

7, Avenue Parmentier
Immeuble Central Parc #2
31200 Toulouse
France

Telephone:
+33-5-34-40-97-40
Facsimile:
+33-5-61-47-86-10
sales@glenair.fr

Glenair Korea

B-1304 Gunpo IT Valley
148 Gosan-Ro, Gunpo-Si
Kyunggi-Do, Korea
435-733

Telephone:
+82-31-8068-1090
Facsimile:
+82-31-8068-1092
sales@glenair.kr

